

NEOS 30 OEM STATIC ELIMINATOR

The NEOS 30 OEM is an innovative long-range static eliminator designed specifically for OEMs.

NEOS 30 OEM is the world's first static eliminator with PLC-automated range control. Ideal for rewinders and all applications where the distance to charged material changes during the process.

PERFORMANCE

- 30 kV of ionising power, automatically optimised to neutralise charge at changing distances.

ESSENTIAL QUALITIES

- A signal from PLC adjusts frequency of NEOS 30 OEM to cope with changing distance to charged material. This achieves continuous optimal performance at distances from 200 mm to 1500 mm without additional sensors.
- Compact size with fully encapsulated electronics.
- Replaceable tungsten emitters guarantee a long life.
- 100 % coverage: effective length = overall length.
- See video on our website.

CONNECTIVITY AND CONTROL

- LED indication of status of bar and whether it needs cleaning. Duplicate remote signals for PLC or to power external lamps, relays.
- Remote on/off switching and standby mode.
- 24 V DC operation.

APPLICATIONS

- NEOS 30 OEM is used on winders, unwinders and many other long range and wide area applications where the target distance can change.



SPECIFICATION

Construction:

Reinforced FR-ABS industrial grade extrusion and endcap, fully encapsulated with epoxy resin. Tungsten emitters.

Output Voltage:

30 kV supply integrated inside bar.

Remote Monitor / Local Status Indication:

2 signals available: 'HV OK' and 'Attention'. Both outputs are IEC 61131-2 Type 1, Type 2 and Type 3 compatible. The outputs can also be used for direct driving of external lamps or relays. Bi-colour LED on endcap for local status indication, including 'Clean Me'.

Electrical Input:

24 V DC (21-28 V), maximum current required 2.5 A. M12 5-pin connector.

Environmental:

0 - 55 °C, 70 % rH non-condensing max. IP66. Fully sealed.

Certification:

CE, CB and UL.

Options:

100 - 250 V AC-DC 24 V Power Supply (Part No: NEOS-PSU)*

NEOS AUTOMATED RANGE CONTROL

The 4-20mA current loop input signal allows the bar output frequency to change as the distance to the charged material changes for optimal electrostatic neutralisation. This additional signal must be supplied by customer equipment to the bar through the 3-pole M8 male connector, mounted on the bar endcap above the M12 connector.

Hardware Specifications

Sensing current range	4 mA – 20 mA
Sense (burden) resistance	250 Ω +/- 1% 5 V drop at 20 mA full-scale
Common-mode voltage range (loop compliance)	0 V – 30 V (up to 6 in series feasible)
Input impedance (common-mode)	>100k Ω
Overload voltage (common-mode, continuous)	60 V
Maximum overload current (continuous)	30 mA
Maximum overload current (<1 s)	50 mA
Connector	M8 male 3-pole

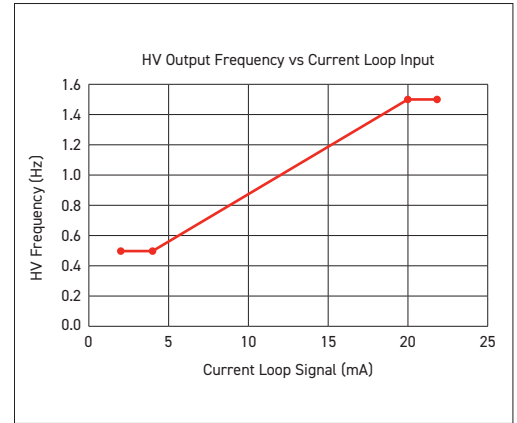

Firmware Specifications

Frequency range	0.5 Hz (4 mA) to 1.5 Hz (20 mA)
Frequency tolerance	+/- 5%
Mapping, frequency to current	Linear
Out-of-range error detection	<2 mA = 0.5 Hz, >22 mA = 1.5 Hz
Response time	<1 s

Custom frequency response available. Contact Fraser for details.

DIMENSIONS AND CONSTRUCTION

Dimensions: 33.6 mm x 76.0 mm (WxH). Available lengths: minimum 600 mm, then 750 mm, then steps of 250 mm to 5000 mm.

Weight: 3.6 kg/m.

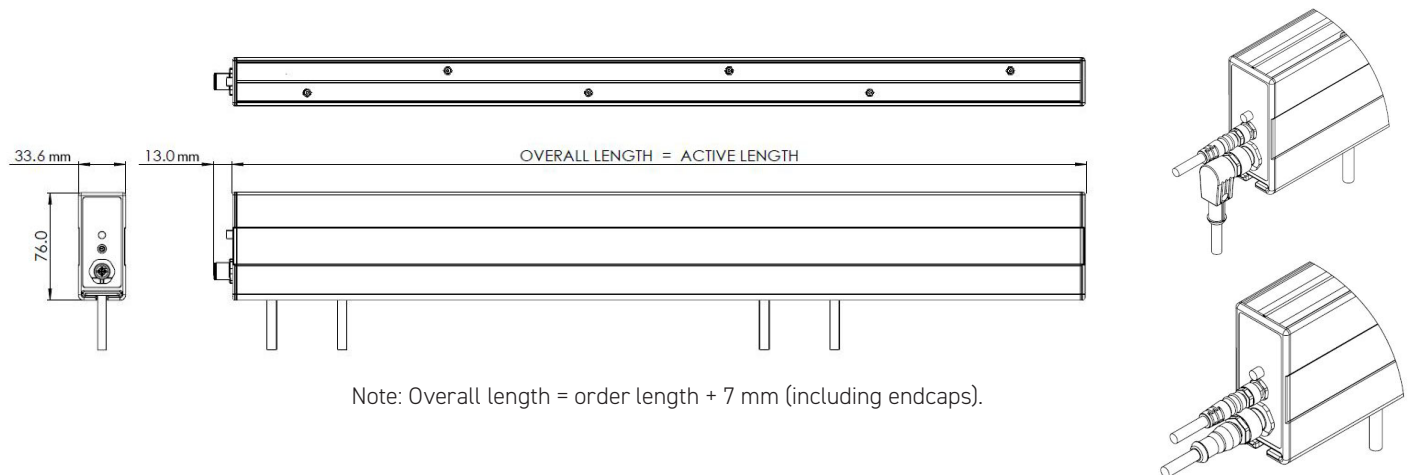

Note: Overall length = order length + 7 mm (including endcaps).

MOUNTING

Each 'T' fixing has two M6 x 40 mm studs and flange nuts.

Two 'T' fixings are supplied for bars up to 1000 mm, plus 1 extra for every additional 500 mm.

Other stud lengths are available, contact the manufacturer for details.

The 'T' fixings slide into the slot in the bottom of the bar.



ACCESSORIES AND SPARES

Description	Part No.
M12 3m cable with 180° connector	81193
M12 5m cable with 180° connector	81194
M12 7.5m cable with 180° connector	81195
M12 10m cable with 180° connector	81196
M8 5m cable with 180° connector	80930
M8 10m cable with 180° connector	80932
Additional Mounting Set	34308

Description	Part No.
M12 3m cable with 90° connector	81199
M12 5m cable with 90° connector	81200
M12 7.5m cable with 90° connector	81201
M12 10m cable with 90° connector	81202
Universal AC-DC 24 V Power Supply *	NEOS-PSU
Fraser Ioniser Cleaning Kit	81220

24 V Cables must be ordered separately. They have standard M12 5-pin female connectors.

* Do not use ANY other standard power supplies with this product. Third party power supplies WILL cause damage and void warranty.