

## Data Sheet

### **EH Analog**

#### Magnetostrictive Linear Position Sensors

- High pressure resistant sensor rod
- Position measurement with more than one magnet
- Small & compact – Ideal for standard hydraulic cylinders

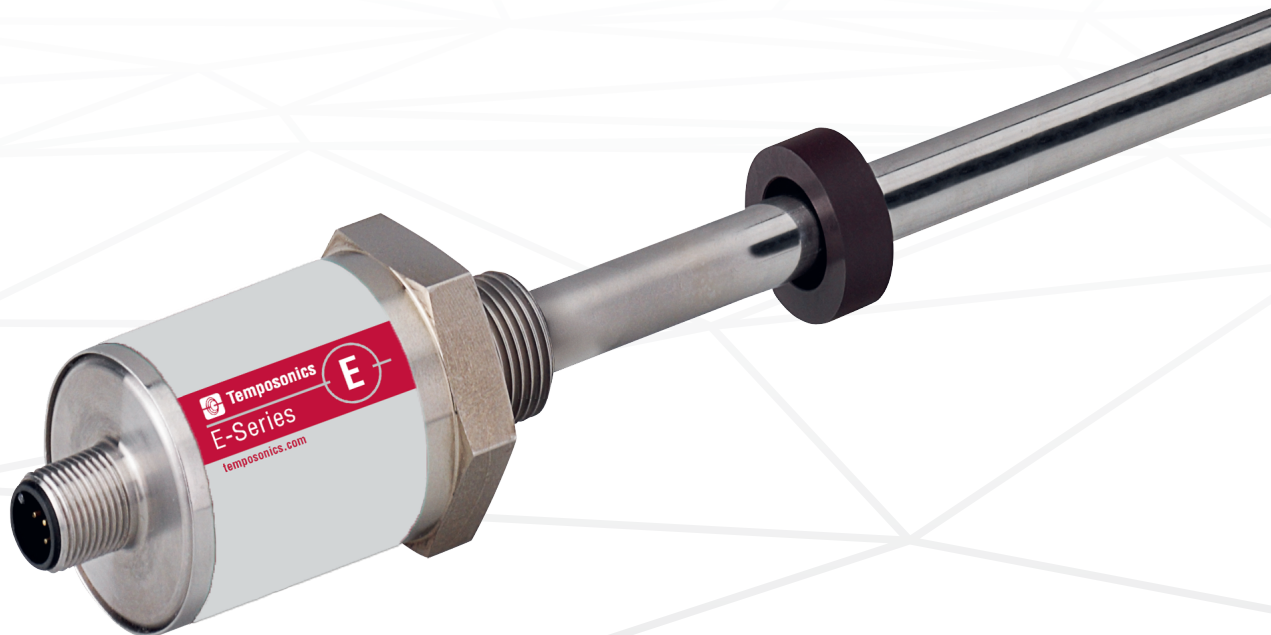

## MEASURING TECHNOLOGY

The absolute, linear position sensors provided by Temposonics rely on the company's proprietary magnetostrictive technology, which can determine position with a high level of precision and robustness. Each Temposonics position sensor consists of a ferromagnetic waveguide, a position magnet, a strain pulse converter and supporting electronics. The magnet, connected to the object in motion in the application, generates a magnetic field at its location on the waveguide. A short current pulse is applied to the waveguide. This creates a momentary radial magnetic field and torsional strain on the waveguide. The momentary interaction of the magnetic fields releases a torsional strain pulse that propagates the length of the waveguide. When the ultrasonic wave reaches the end of the waveguide it is converted into an electrical signal. Since the speed of the ultrasonic wave in the waveguide is precisely known, the time required to receive the return signal can be converted into a linear position measurement with both high accuracy and repeatability.

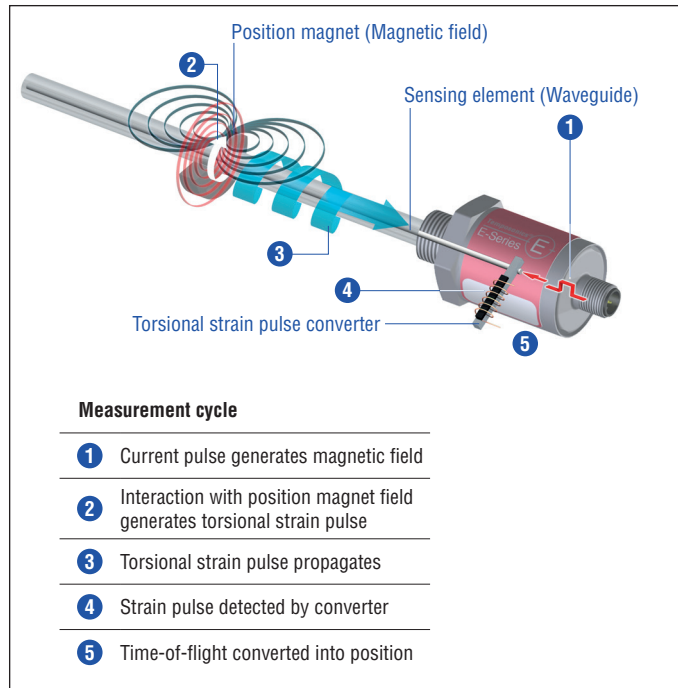

Fig. 1: Time-of-flight based magnetostrictive position sensing principle

## EH SENSOR

Robust, non-contact and wear free, the Temposonics linear position sensor provide the best durability and precise position measurement feedback in harsh industrial environments. Measurement accuracy is tightly controlled by the quality of the waveguide manufactured exclusively by Temposonics.

Temposonics® EH is a compact rod-style sensor and the ideal solution for direct stroke measurement in small hydraulic cylinders. The position magnet mounted on the piston head of the hydraulic cylinder travels over the sensor rod with the built-in waveguide to provide a precise, non-contact position measurement. The EH is ideal for a variety of applications including: fluid power, food industry, plastic industry, glass and ceramics, energy sector, machine tools and testing machines.



Fig. 2: Typical application: Plastics processing

## TECHNICAL DATA

Output	
Voltage	0...10 VDC or 10...0 VDC, 0...10 VDC and 10...0 VDC (controller input resistance $R_L > 5 \text{ k}\Omega$ )
Current	4...20 mA or 20...4 mA (minimum / maximum load: 0 / 500 $\Omega$ )
Measured value	Position, option: Multi-position measurement with maximum 2 magnets
Measurement parameters	
Resolution	Infinite
Cycle time	Typ. 0.3 ms < t < 2 ms (depending on stroke lengths)
Linearity <sup>1</sup>	$\leq \pm 0.02 \%$ F.S. (minimum $\pm 60 \mu\text{m}$ )
Repeatability	$\leq \pm 0.005 \%$ F.S. (minimum $\pm 20 \mu\text{m}$ )
Operating conditions	
Operating temperature	-40...+75 °C (-40...+167 °F)
Humidity	90 % rel. humidity, no condensation
Ingress protection <sup>2</sup>	IP67 / IP69K if mating cable connector is correctly fitted
Shock test	100 g (single shock) IEC standard 60068-2-27
Vibration test	15 g / 10...2000 Hz IEC standard 60068-2-6 (resonance frequencies excluded)
EMC test	Electromagnetic emission according to EN 61000-6-3 Electromagnetic immunity according to EN 61000-6-2 The sensor meets the requirements of the EC directives and is marked with  .
Magnet movement velocity	Any
Design / Material	
Sensor electronics housing	Stainless steel 1.4305 (AISI 303); option: Stainless steel 1.4404 (AISI 316L)
Sensor rod	7 mm (0.28 in.) rod-Ø: Stainless steel 1.4301 (AISI 304) 10 mm (0.39 in.) rod-Ø: Stainless steel 1.4306 (AISI 304L); option: Stainless steel 1.4404 (AISI 316L)
Stroke length	50...2540 mm (2...100 in.)
Operating pressure	7 mm (0.28 in.) rod-Ø: 300 bar (4351 psi), 450 bar (6527 psi) peak 10 mm (0.39 in.) rod-Ø: 350 bar (5076 psi), 530 bar (7687 psi) peak
Mechanical mounting	
Mounting position	Any
Mounting instruction	Please consult the technical drawings and the brief instructions (document number: <a href="#">551684</a> )
Electrical connection	
Connection type	M12 (5 pin) male connector
Operating voltage	+24 VDC (-15 / +20 %); UL recognition requires an approved power supply with energy limitation (UL 61010-1), or Class 2 rating according to the National Electrical Code (USA) / Canadian Electrical Code.
Ripple	$\leq 0.28 V_{pp}$
Current consumption	50...140 mA
Dielectric strength	500 VDC (DC ground to machine ground)
Polarity protection	Up to -30 VDC
Overvoltage protection	Up to 36 VDC

1/ With position magnet # 251 416-2. Not applied for customized version (CP11009)

2/ The IP rating is not part of the UL recognition

## TECHNICAL DRAWING

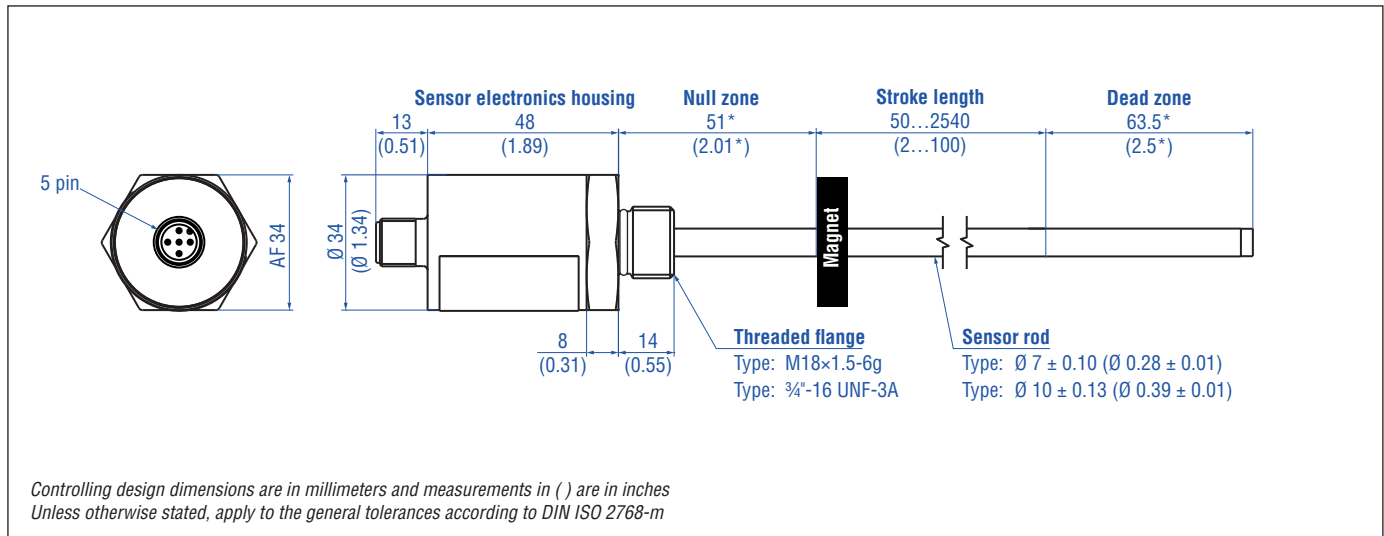

## CONNECTOR WIRING

### D34

M12 A-coded	Pin	Function
	1	+24 VDC (-15 / +20 %)
	2	Output 1
	3	DC Ground (0 V)
	4	Output 2
	5	DC Ground

\*Use prefix CP11009 to the order code for start position of 30 mm (1.18 inch) and 60 mm (2.36 inch) dead zone.

**FREQUENTLY ORDERED ACCESSORIES** – Additional options available in our [Accessories Guide](#) 551444

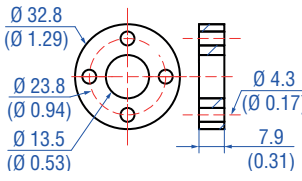
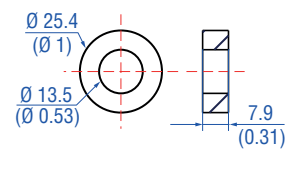
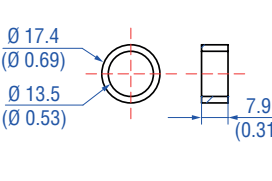
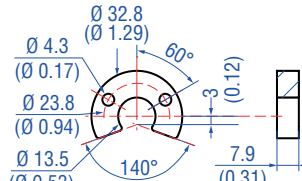
Position magnets			
			
<p><b>Standard ring magnet</b> Part no. 201 542-2</p>	<p><b>Ring magnet OD25.4</b> Part no. 400 533</p>	<p><b>Ring magnet OD17.4</b> Part no. 401 032</p>	<p><b>U-magnet OD33</b> Part no. 251 416-2</p>
<p>Material: PA ferrite GF20 Weight: Ca. 14 g Operating temperature: -40...+105 °C (-40...+221 °F) Surface pressure: Max. 40 N/mm<sup>2</sup> Fastening torque for M4 screws: 1 Nm</p>	<p>Material: PA ferrite Weight: Ca. 10 g Operating temperature: -40...+105 °C (-40...+221 °F) Surface pressure: Max. 40 N/mm<sup>2</sup></p>	<p>Material: PA neobind Weight: Ca. 5 g Operating temperature: -40...+105 °C (-40...+221 °F) Surface pressure: Max. 20 N/mm<sup>2</sup></p>	<p>Material: PA ferrite GF20 Weight: Ca. 11 g Operating temperature: -40...+105 °C (-40...+221 °F) Surface pressure: Max. 40 N/mm<sup>2</sup> Fastening torque for M4 screws: 1 Nm</p>

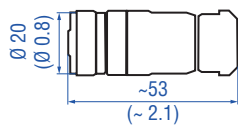
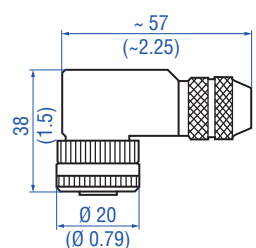
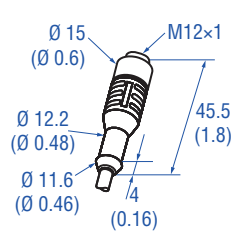
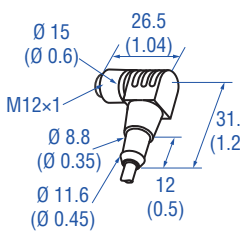
Cable connectors <sup>3</sup>		Cord sets	
			
<p><b>M12 (5 pin) female, straight</b> Part no. 370 677</p>	<p><b>M12 (5 pin) female, angled</b> Part no. 370 678</p>	<p><b>M12 (5 pin) female, straight</b> Part no. 370 673</p>	<p><b>M12 (5 pin) female, angled</b> Part no. 370 675</p>
<p>Housing: GD-Zn, Ni / IP67 Termination: Screw; max. 0.75 mm<sup>2</sup> Contact insert: CuZn Cable Ø: 4...8 mm (0.16...0.31 in.) Fastening torque: 0.6 Nm</p>	<p>Housing: GD-Zn, Ni / IP67 Termination: Screw; max. 0.75 mm<sup>2</sup> Contact insert: CuZn Cable Ø: 5...8 mm (0.2...0.31 in.) Fastening torque: 0.6 Nm</p>	<p>Ingress protection: IP67 Cable: Shielded, pigtail end Cable length: 5 m (16.4 ft.)</p>	<p>Ingress protection: IP67 Cable: Shielded, pigtail end Cable length: 5 m (16.4 ft.)</p>

<sup>3</sup>/ Follow the manufacturer's mounting instructions when connecting the connectors  
Controlling design dimensions are in millimeters and measurements in ( ) are in inches

## ORDER CODE

1	2	3	4	5	6	7	8	9	10	11	12	13	14	15
E	H							D	3	4	1			
a		b	c					d			e	f		

a	Sensor model
E H	Rod

b	Design
	<b>EH rod-style sensor with housing material 1.4305 (AISI 303) and rod material 1.4301 (AISI 304)</b>
K	Flange M18×1.5-6g, 7 mm rod-Ø
L	Flange ¾"-16 UNF-3A, 7 mm rod-Ø
	<b>EH rod-style sensor with housing material 1.4305 (AISI 303) and rod material 1.4306 (AISI 304L)</b>
M	Flange M18×1.5-6g, 10 mm rod-Ø
S	Flange ¾"-16 UNF-3A, 10 mm rod-Ø
	<b>EH rod-style sensor with housing material 1.4404 (AISI 316L) and rod material 1.4404 (AISI 316L)</b>
F	Flange ¾"-16 UNF-3A, 10 mm rod-Ø
W	Flange M18×1.5-6g, 10 mm rod-Ø

c	Stroke length
X X X X M	0050...2540 mm
X X X X U	002.0...100.0 in.

### Standard stroke length (mm)\*

Stroke length	Ordering steps
50 ... 500 mm	5 mm
500 ... 750 mm	10 mm
750...1000 mm	25 mm
1000...2540 mm	50 mm

### Standard stroke length (in.)\*

Stroke length	Ordering steps
2 ... 20 in.	0.2 in.
20 ... 30 in.	0.5 in.
30 ... 40 in.	1.0 in.
40...100 in.	2.0 in.

d	Connection type
D 3 4	M12 (5 pin) male connector

e	Operating voltage
1	+24 VDC (-15 / +20 %)

f	Output
<b>Voltage</b>	
V 0 1	0...10 VDC (1 output channel with 1 position magnet)
V 1 1	10...0 VDC (1 output channel with 1 position magnet)
V 0 2	0...10 VDC (2 output channels with 2 position magnets)
V 1 2	10...0 VDC (2 output channels with 2 position magnets)
V 0 3	0...10 VDC and 10...0 VDC (2 output channels with 1 position magnet)
<b>Current</b>	
A 0 1	4...20 mA (1 output channel with 1 position magnet)
A 1 1	20...4 mA (1 output channel with 1 position magnet)
A 0 2	4...20 mA (2 output channels with 2 position magnets)
A 1 2	20...4 mA (2 output channels with 2 position magnets)

## DELIVERY



Sensor, O-ring

Accessories have to be ordered separately.

Operation manuals & software are available at:  
[www.temposonics.com](http://www.temposonics.com)

\* / Non standard stroke lengths are available; must be encoded in 5 mm / 0.1 in. increments

**UNITED STATES**  
**Temposonics, LLC**  
Americas & APAC Region  
3001 Sheldon Drive  
Cary, N.C. 27513  
Phone: +1 919 677-0100  
E-mail: info.us@temposonics.com

---

**GERMANY**  
**Temposonics**  
**GmbH & Co. KG**  
EMEA Region & India  
Auf dem Schüffel 9  
58513 Lüdenscheid  
Phone: +49 2351 9587-0  
E-mail: info.de@temposonics.com

---

**ITALY**  
Branch Office  
Phone: +39 030 988 3819  
E-mail: info.it@temposonics.com

---

**FRANCE**  
Branch Office  
Phone: +33 6 14 060 728  
E-mail: info.fr@temposonics.com

---

**UK**  
Branch Office  
Phone: +44 79 44 15 03 00  
E-mail: info.uk@temposonics.com

---

**SCANDINAVIA**  
Branch Office  
Phone: + 46 70 29 91 281  
E-mail: info.sca@temposonics.com

---

**CHINA**  
Branch Office  
Phone: +86 21 2415 1000 / 2415 1001  
E-mail: info.cn@temposonics.com

---

**JAPAN**  
Branch Office  
Phone: +81 3 6416 1063  
E-mail: info.jp@temposonics.com

---

**Document Part Number:**  
551647 Revision I (EN) 02/2018



**temposonics.com**