

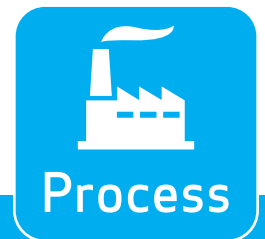

Series S . S40-P



Panel meter for process signals

PANEL METERS

Panel meter for process signals in mA and Vdc, in compact size 72 x 36 mm, and standard 14 mm digit height. Provides configurable excitation voltage to power-up the transducer. Reading with 4 digit display. Segment linearization, fast access to alarm setpoints, tare function, 'on power up' function, 'measure' function, configurable reading brightness. Universal AC and DC power. Up to 2 optional modules for output and control (relays, transistor, control SSR, analog outputs, Modbus RTU communications, RS-485 ASCII, RS-232, ...)

1. Panel meter S40-P

Panel meter in compact 72 x 36 mm size for process signals

Panel meter in compact 72 x 36 mm size, for process signals in mA and Vdc, with 14 mm digit height. Provides excitation voltage configurable from +5 Vdc to +20 Vdc (max. 35 mA) to power up transducers. Reading with 4 digits scalable to 9999 / -1999 with selectable decimal point position.

Options for output and control with 1 and 2 relays, transistor outputs, controls for SSR relays, isolated analog outputs, communications in Modbus RTU, RS-485 ASCII and RS-232. Special options with 4 relay outputs.

Independent alarms configurable as maximum or minimum, with 1 or 2 setpoints per alarm, hysteresis, independent activation and deactivation delays and control for inverted relay.

Front protection IP54. Connections by plug-in screw terminals. For industrial applications.

- up to 20 segments for signal linearization (see section 1.10.5)
- **'Fast access'** menu to selected functions, accessible with key UP (▲) (see section 1.10.6)
- **'Field correction'** for fast and easy on-the-field correction of signal offsets (see section 1.10.2)
- **'Tare'** function for load-cell and weight applications (see section 1.10.9)
- **'On power up'** for system protection on first 'cold' start-up (see section 1.10.8)
- **'Peak & hold'** for test-break applications (see section 1.10.4)

Multiple display filters, memory for maximum and minimum reading, password protection, 5 brightness levels.

1.1 How to order

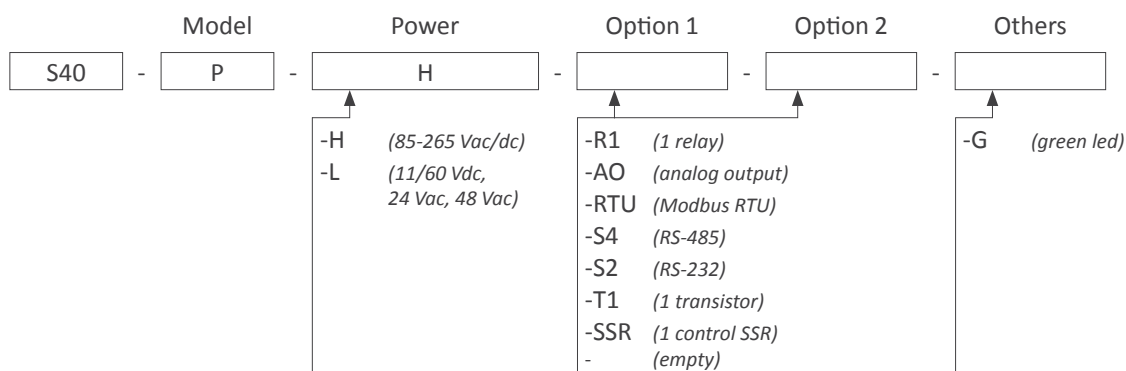

Index

1. Panel meter S40-P	2	1.10.14 Firmware version.	11
1.1 How to order	2	1.10.15 Brightness	11
1.2 Front view	3	1.10.16 Access to optional modules	11
1.3 Rear view	3	1.11 Full configuration menu	12
1.4 Power connections	3	1.12 To access the instrument	14
1.5 Signal connections	3	1.13 Modular system	14
1.6 Mechanical dimensions (mm)	3	1.14 Precautions on installation	15
1.7 Technical specifications	4	1.15 Factory configuration	15
1.8 How to operate the menus	5	1.16 Warranty	15
1.9 Messages and errors	5	1.17 CE declaration of conformity	15
1.10 Configuration menu.	6	2. Output and control modules	16
1.10.1 Initial set-up	6	2.1 Module R1.	16
1.10.2 Field correction	6	2.2 Module T1.	16
1.10.3 Alarms	7	2.3 Module SSR	17
1.10.4 Display filters.	8	2.4 Module AO	17
1.10.5 Segment linearization	9	2.5 Module RTU.	18
1.10.6 Fast access	9	2.6 Module S4.	18
1.10.7 Super fast access	9	2.7 Module S2.	19
1.10.8 Menu 'On Power Up'	10	2.8 Modules R2, R4	19
1.10.9 Menu 'Tare function'	10		
1.10.10 Menu 'Key LE'	10		
1.10.11 Excitation voltage	11		
1.10.12 Function 'Password'	11		
1.10.13 Factory reset	11		

1.2 Front view

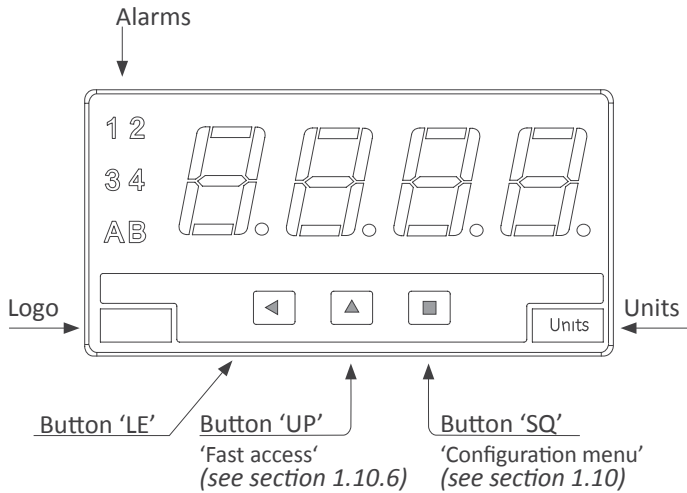

1.3 Rear view

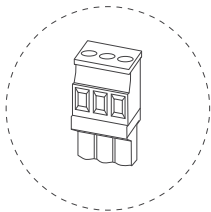
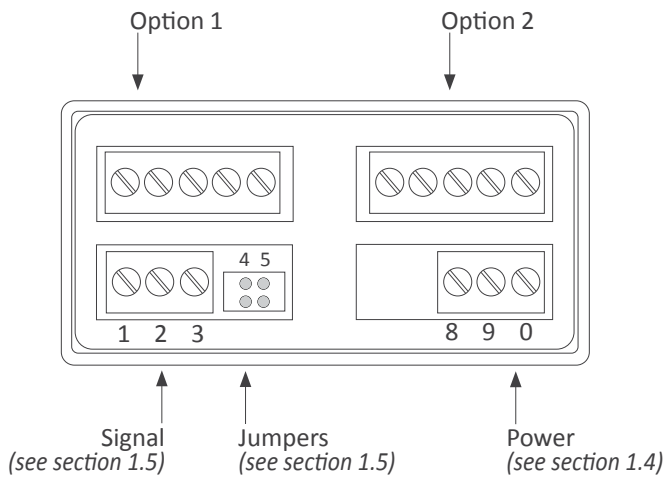

Detail of the plug-in screw terminals provided with the instrument. The instrument is provided with all terminals needed, both male and female.

1.4 Power connections

Earth connection - Although a terminal is provided for earth connection, this connection is optional. The instrument does not need earth connection for correct operation nor for compliance with the security regulations.

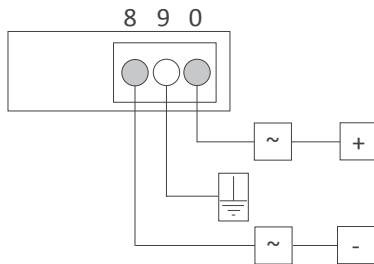

Fuse - To comply with security regulation 61010-1, add to the power line a protection fuse acting as disconnection element, easily accessible to the operator and identified as a protection device.

Power 'H' fuse 250 mA time lag
 Power 'L' fuse 400 mA time lag

1.5 Signal connections

Bucle de corriente activo 4/20 mA, ± 20 mA

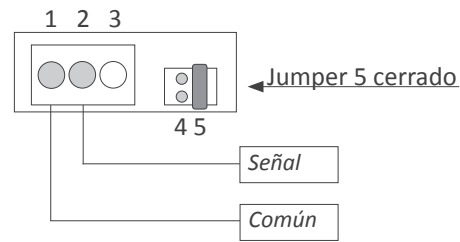

Bucle de corriente pasivo 4/20 mA, ± 20 mA

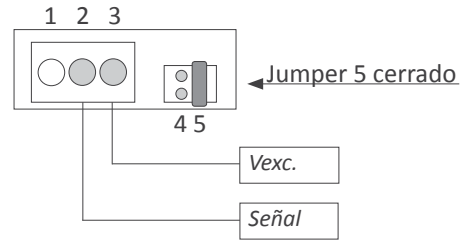

Señal de voltaje activa 0/10 Vdc, ± 10 Vdc

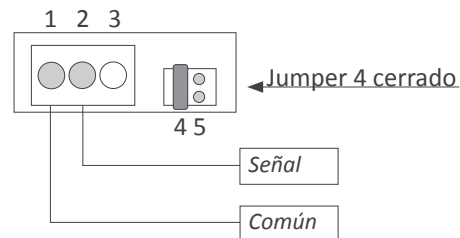

Señal de voltaje pasiva 0/10 Vdc, ± 10 Vdc

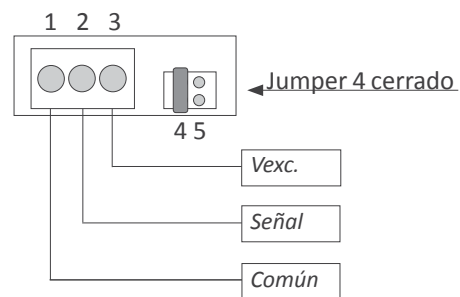

1.6 Mechanical dimensions (mm)

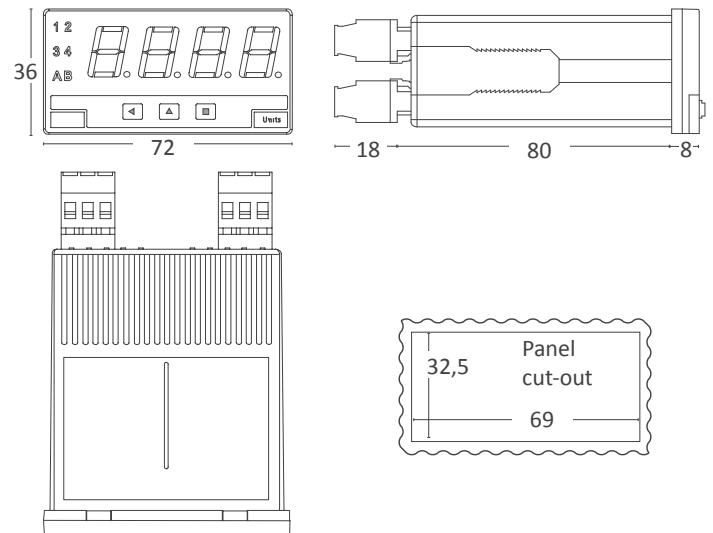

1.7 Technical specifications

Digits	
number of digits	4
led	7 segments led
color	red or green
digit height	14 mm
Reading	
maximum reading*	9999
minimum reading*	-1999
decimal point	configurable X.X.X.X.
acquisitions	15 readings / second
display refresh	15 readings / second
step response	<120 mSec. (0 % to 99 % signal)
overrange	flash reading (see section 1.9)
underrange	flash reading (see section 1.9)
Signal ranges	(see Table 1)
Accuracy at 25 °C	(see Table 1)
Thermal drift	(see Table 1)
Excitation voltage	configurable
voltage	+20 Vdc, +15 Vdc, +10 Vdc, +5 Vdc
accuracy	±5 %
maximum current	35 mA
protection	short circuit protected

Functions included		Section
Segment linearization	up to 20 segments	1.10.5
Display filters	recursive steps fixed digits left zeros	1.10.4
Memory	max. and min. readings	1.10.4
Password	configuration block	1.10.12
'Measure'	yes	1.10.6
'Field correction'	yes, high and low signals	1.10.2
'Peak & Hold'	yes	1.10.4
Alarms	double setpoints activation delays deactivation delays hysteresis inverted relays locked alarms	1.10.3
Display brightness	5 levels	1.10.15
'Fast access'	yes	1.10.6
'Tare' function	yes	1.10.9
'On Power Up'	yes	1.10.8

Table 2 - Functions included

Ranges	Accuracy	Zin	Max. signal overload	Offset drift	span drift* *includes offset drift
4/20 mA	0.05 % FS	11 Ohm	100 mA permanent	10 ppm/°C	25 ppm/°C
0/10 Vdc	0.05 % FS	932 KOhm	100 Vdc permanent	10 ppm/°C	25 ppm/°C
±20 mA	0.05 % FS	11 Ohm	100 mA permanent	10 ppm/°C	25 ppm/°C
±10 Vdc	0.05 % FS	932 KOhm	100 Vdc permanent	10 ppm/°C	25 ppm/°C

Table 1 - Input signal range specifications

Power		Mechanical	
power 'H'	85 a 265 Vac/dc	mounting	panel
power 'L'	11 a 60 Vdc y 24/48 Vac	connections	plug-in screw terminal
isolation*	2500 Veff with power 'H' 1500 Veff with power 'L' *all units tested during 60 seconds	housing material	ABS, polycarbonate (V0)
consumption	<1.5 W only meter <4.0 W meter with options	weight	<150 grams
Configuration	3 buttons front keypad (and rear jumper)	front size	72 x 36 mm
Front protection	IP54	panel cut-out	69 x 32.5 mm
Output and control options	relays, analog outputs, serial communications, ... (see section 2)	depth from panel	98 mm (including terminals)
		Temperature	
		operation	from 0 to +50 °C
		storage	from -20 to +70 °C
		warm-up time	15 minutes

1.8 How to operate the menus

The instrument has two menus accessible to the user :

'Configuration menu' (key SQ) (■)

'Fast access' menu (key UP) (▲)

Configuration menu

The 'configuration menu' modifies the configuration parameters to adapt the instrument to the application needs. To access the 'configuration menu' press for 1 second the SQ (■) key. This access can be blocked by activating the 'Password' ('PASS') function. While operating the 'configuration menu', the alarm status is 'hold' to the status they had before accessing the menu, and the output and control modules remain in 'error' state. When leaving the 'configuration menu', the instrument applies a system reset, followed by a brief disconnection of the alarms and the output and control modules. Functionality is then recovered.

For a detailed explanation on the 'configuration menu' see section 1.10, and for a full view of the 'configuration menu' structure see section 1.11.

'Fast access' menu

The 'fast access' menu is an operator configurable menu, providing fast and direct access to the most usual functions of the instrument with a single key pad stroke. Press key UP (▲) to access this menu.

See section 1.10.6 for a list of functions eligible for 'fast access' in this instrument. The 'Password' ('PASS') function does not block access to this menu. Accessing and modifying parameters in the 'fast access' menu does not interfere with the normal functionality of the instrument, and it does not generate any system reset when validating the changes.

Front key pad description

Key SQ (■) - press the SQ (■) key for 1 second to access the 'configuration menu'. Inside the menu, the SQ (■) key functions as a 'ENTER' key. It selects and accesses the menu option currently displayed. At menus with numerical value entries, it validates the number displayed.

Key UP (▲) - the UP (▲) key gives access to the 'fast access' menu. Inside the menus, it moves vertically through the different menu options. At menus with numerical value entries, it modifies the digit selected by increasing its value to 0, 1, 2, 3, 4, 5, 6, 7, 8, 9.

Key LE (◀) - inside the menus, the LE (◀) key functions as the 'ESCAPE' key. It leaves the selected menu, and eventually, will leave the whole menu. When leaving the 'configuration menu' with the LE (◀) key, the changed parameters are activated. At menus with numerical value entries, the LE (◀) key allows to select the active digit. To modify the value of the selected digit use the UP (▲) key.

Menu 'rollback'

After 30 seconds without interaction from the operator, the instrument will rollback and leave the 'configuration menu' or the 'fast access' menu. All changes will be discarded.

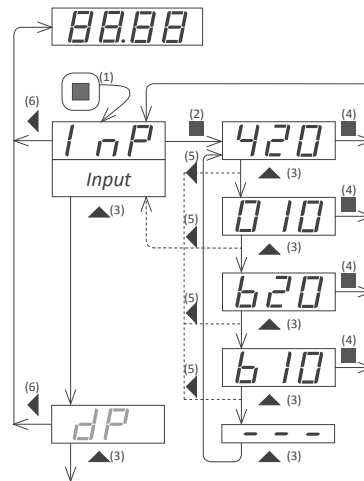

Example of operation inside the 'configuration menu'.

1. The SQ (■) key enters into the 'configuration menu'.
2. The SQ (■) key enters into the 'InP' option menu.
3. The UP (▲) key moves through the menu options.
4. The SQ (■) key selects the desired range and returns to the 'InP' menu.
5. The LE (◀) key leaves the actual menu level and moves to the previous menu level.
6. The LE (◀) key leaves the 'configuration menu'. Changes are applied and saved at this moment.

1.9 Messages and errors

The error messages are shown on display in flash mode.

Messages and errors	
'h.udr' 'h.ovr'	Hardware underrange ('h.udr') / overrange ('h.ovr'). Input signal is lower / higher than the minimum / maximum signal the instrument can detect.
'd.udr' 'd.ovr'	display underrange ('d.udr') / overrange ('d.ovr'). The instrument already displays the minimum / maximum value possible (-1999 / 9999).
'hoLd'	the 'hold' function is active. Display is on hold.
'P.hLd'	the 'Peak&Hold' function is active.
'Err.0'*	at the 'scaling' ('ScAL') menu entry, the defined slope is higher than '5000' (slope almost vertical). Entered values are dismissed and default values are activated.
'Err.1'	incorrect password.
'Err.2'	at 'oPt.X' menu entry. Installed module is not recognized.
'Err.3'	at 'segment linearization' ('SLin') menu entry. The 'input X' values entered are not in growing succession.
'Err.5'*	at 'segment linearization' ('SLin') menu entry. the defined slope is higher than '5000' (slope almost vertical). Entered values are dismissed and default values are activated
'Err.8'	excitation voltage overload.

Table 3 - Messages and error codes

*slope calculation for errors 'Err.0' y 'Err.5'.

$$\frac{(dHl-dLo) \text{ [counts]}}{(Ih-Ilo) \text{ [mA or Vdc]}} < 5000$$

1.10 Configuration menu

Press 'SQ' (■) for 1 second to access the 'configuration menu'. For a description on how to operate inside the menus see section 1.8. For a full vision of the 'configuration menu' structure see section 1.11.

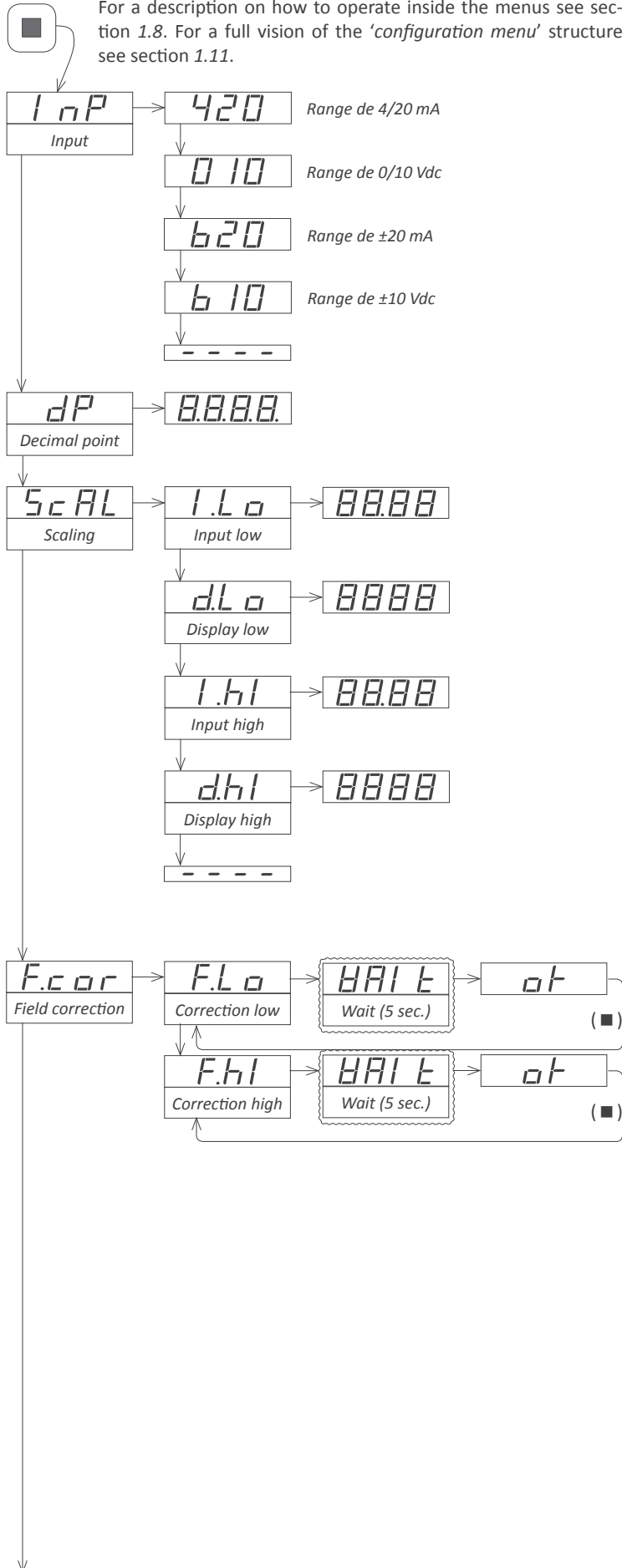

1.10.1 Initial set-up

To configure the initial set up of the instrument, select the input signal range, the decimal point position, and scale the reading.

Access the 'Input' ('InP') menu to select the input signal range. Options available are 4/20 mA, 0/10 Vdc, ±20 mA y ±10 Vdc. Select the rear jumper at position '4' for Vdc or '5' for mA (see section 1.5).

Access the 'Decimal point' ('dP') menu to select the decimal point position. Move the decimal point by pressing the 'LE' (◀) key.

Scale the reading at the 'Scaling' ('ScAL') menu. There are four parameters to configure :

- 'Input low' ('ILo') - minimum input signal, in mA or Vdc with two decimals.
- 'Display low' ('dLo') - reading associated to the minimum input signal.
- 'Input high' ('IhI') - maximum input signal, in mA or Vdc with two decimals..
- 'Display high' ('dhI') - reading associated to the maximum input signal.

1.10.2 Field correction

The 'Field correction' ('F.cor') functions allows to correct the instrument scaling parameters, when the instrument is being installed on the field, providing a fast and easy way to compensate offset signals.

To operate the 'Field correction' ('F.cor') function for the offset correction, generate the minimum input signal and access the 'Field low' ('F.Lo') function. Then the following sequence will start

- message with signal type ('mA' or 'Vdc')
- message 'wait' ('WAIt') in flash mode
- after 5 seconds, message 'ok' ('oK') appears
- at this point, press key SQ ('■')
- the menu returns to menu entry 'Field Low' ('F.Lo')

The instrument has read the input signal and automatically configures the 'Input low' ('I.Lo') for you.

Repeat the process generating the maximum input signal and access the 'Field high' ('F.hI') menu. The instrument will read the input signal and automatically configure the 'Input high' ('I.hI') parameter to match the signal read.

Application - a 0/10 Bar pressure transmitter provides a 4/20 mA output signal. At installation, the operator detects that the reading at 0 Bar is 0.34 Bar and that at 10 Bar the reading is 10.72 Bar. Apply the 'Field correction' / 'F.Lo' function while reading is 0.34 Bar and the instrument will automatically correct the reading to 0.00 Bar. Afterwards, apply the 'Field correction' / 'F.HI' function while reading is 10.72 Bar and the instrument will automatically correct the reading to 10.00 Bar.

1.10 Configuration menu (cont.)

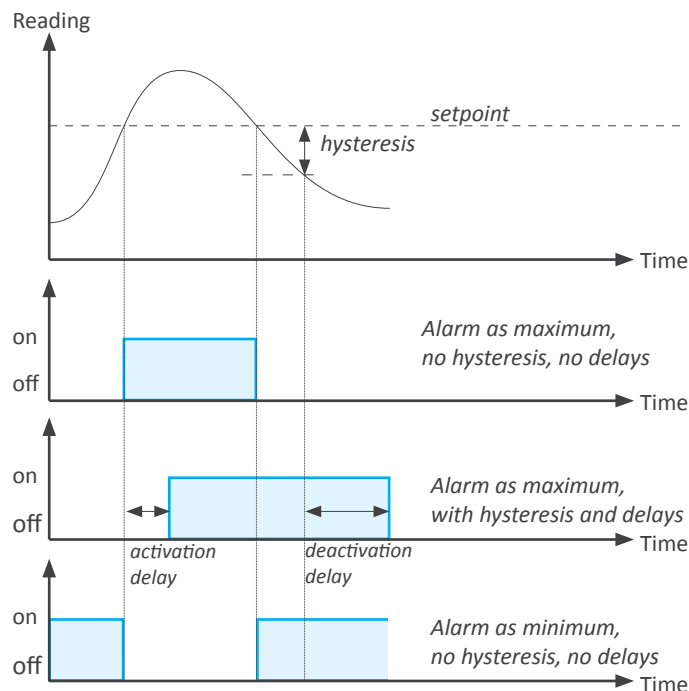
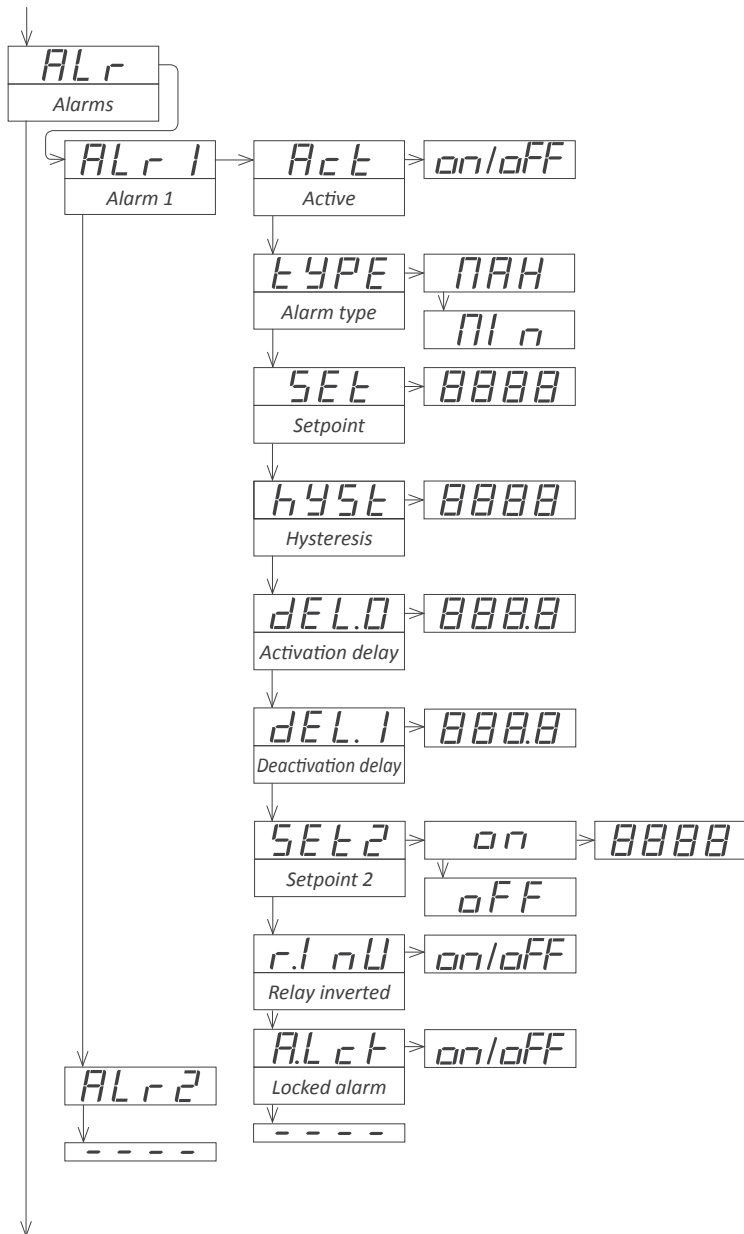

1.10.3 Alarms

The 'Alarms' ('ALr') menu configures the independent activation of up to 2 relay outputs (or transistor or control SSR), installed with the R1 (or T1 or SSR) optional modules (see section 2.1). For outputs up to 4 relays, see special modules R2 and R4 at section 2.8. The alarm states are indicated in the front display with leds marked as '1' and '2'.

To configure an alarm, enter into the alarm menu ('ALr1' or 'ALr2') and configure the following parameters :

- select 'Active' ('Act') to 'on'
- at 'Alarm type' ('Type') select the alarm acting as a maximum type alarm ('MAX') or a minimum type alarm ('Min'). The maximum type alarm (or minimum type alarm) activates when the display value is higher (or lower) than the setpoint value.
- at 'Setpoint' ('Set') enter the value for the alarm activation point. This parameter is eligible for configuration through the 'Fast access' menu (see section 1.10.6).
- configure the hysteresis value at 'Hysteresis' ('hyst'). The hysteresis applies to the deactivation process of the alarm. The alarm deactivates when the reading has passed the setpoint value plus the hysteresis value. Hysteresis helps to avoid repetitive switching of the alarm relays, due to fluctuating input signals around the setpoint.
- at 'Activation delay' ('dEL.0') configure the delay to apply before alarm activation. The activation delay starts counting when the setpoint value is passed. Value from 0.0 to 99.9 seconds.
- at 'Deactivation delay' ('dEL.1') configure the delay to apply before alarm deactivation. The deactivation delay starts counting when the setpoint value plus the hysteresis value, is passed. Value from 0.0 to 99.9 seconds.
- to work with 'windowed alarms' (see graphical example below) activate 'Setpoint 2' ('Set2') to 'on' and then configure the desired second setpoint value. Second setpoint must always be higher in value than the first setpoint.
- the 'Relay inverted' ('r.Inv') parameter inverts the normal relay connections. When set to 'on' the relay will be active when alarm is inactive. For security applications where an inactive setpoint controls the shutdown of the system.
- the 'Locked alarm' ('A.Lck') parameter disables the automatic deactivation of the alarm. Alarm deactivation must be performed manually, by pressing the 'LE' front button (see section 1.10.10)

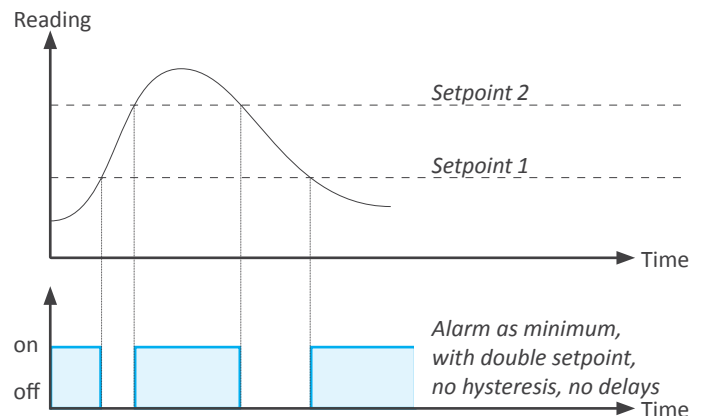

1.10 Configuration menu (cont.)

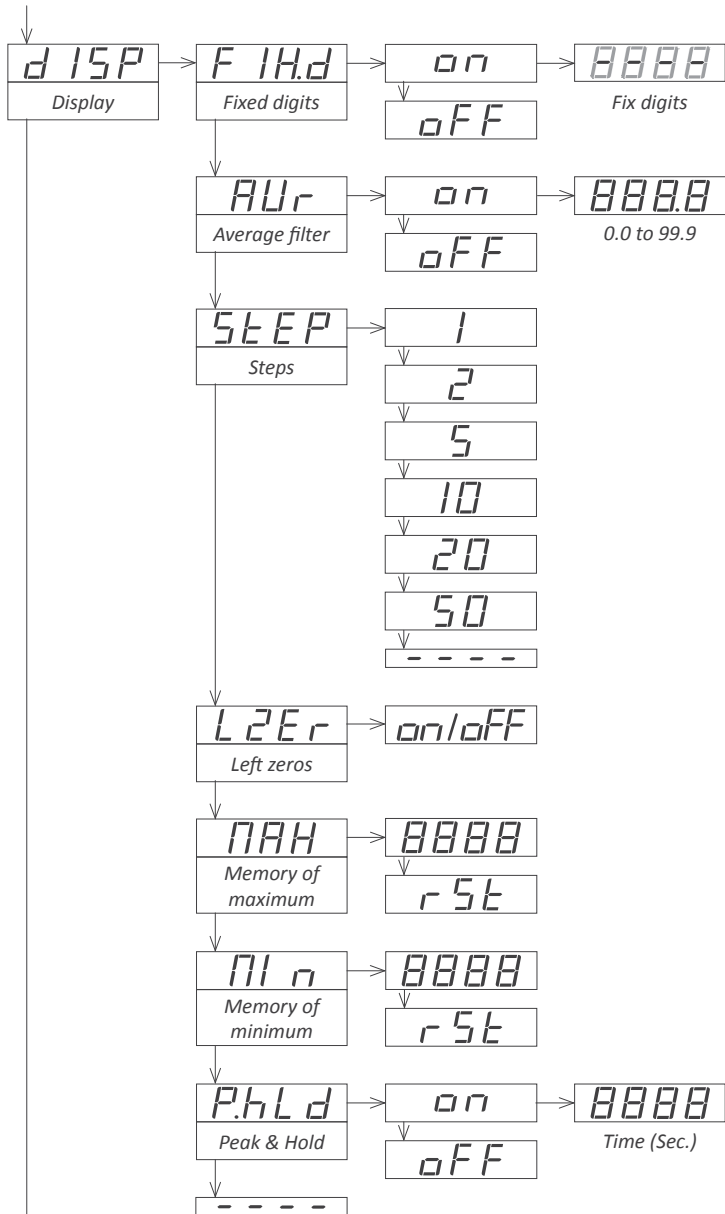

1.10.4 Display filters

The instrument provides several functions to personalize the reading of the display values

- the **'Fixed Digits'** ('FIX.d') allows to fix each digit to a fixed value. As an example, fix the least significant digit to a '0' in order to block noisy fluctuations. To fix a digit, all digits to its right must be also fixed. Value '-' means that the digit is not fixed.
- the **'Average filter'** ('AVr') function allows to reduce reading oscillations due to noisy signals. It applies a recursive filter on the reading value. To activate the average filter set 'AVr' to 'on' and assign the filter strength between '0.0' and '99.9'. Higher values activate stronger filter. Stronger filters slow down the reading changes.
- the **'Steps'** ('StEP') function allows to define minimum reading steps, which will be done in steps of 1, 2, 5, 10, 20 or 50 counts.

Example - selecting a step of 20 configures the reading to change in steps of 20 counts ('1420', '1440', '1460', ...).

- the **'Left Zero'** ('LZEr') function lights all zeros to the left.
- the **'Memory of maximum'** ('MAX') function displays the maximum reading value stored in memory. It also provides a way to reset the value. This parameter is eligible for configuration through the 'Fast access' menu (see section 1.10.6).
- the **'Memory of minimum'** ('MAX') function displays the minimum reading value stored in memory. It also provides a way to reset the value. This parameter is eligible for configuration through the 'Fast access' menu (see section 1.10.6).

- the **'Peak & hold'** ('P.hLD') function visualizes and hold the maximum reading. For test-break applications, where the meter always increases its value until the unit under test breaks and the signal falls down. The meter maintains the maximum reading before the signal fell down.

To free the 'hold' reading, press any of the front key pad or wait the time configured at the 'time' parameter.

- Time 0 hold disabled (Off)
- Time 1 a 3999 seconds waiting
- Time 4000 infinite hold

While 'hold' is active, the instrument alarms are still associated to the input signal, therefore still providing control to disconnect the application once the test has finished.

1.10 Configuration menu (cont.)

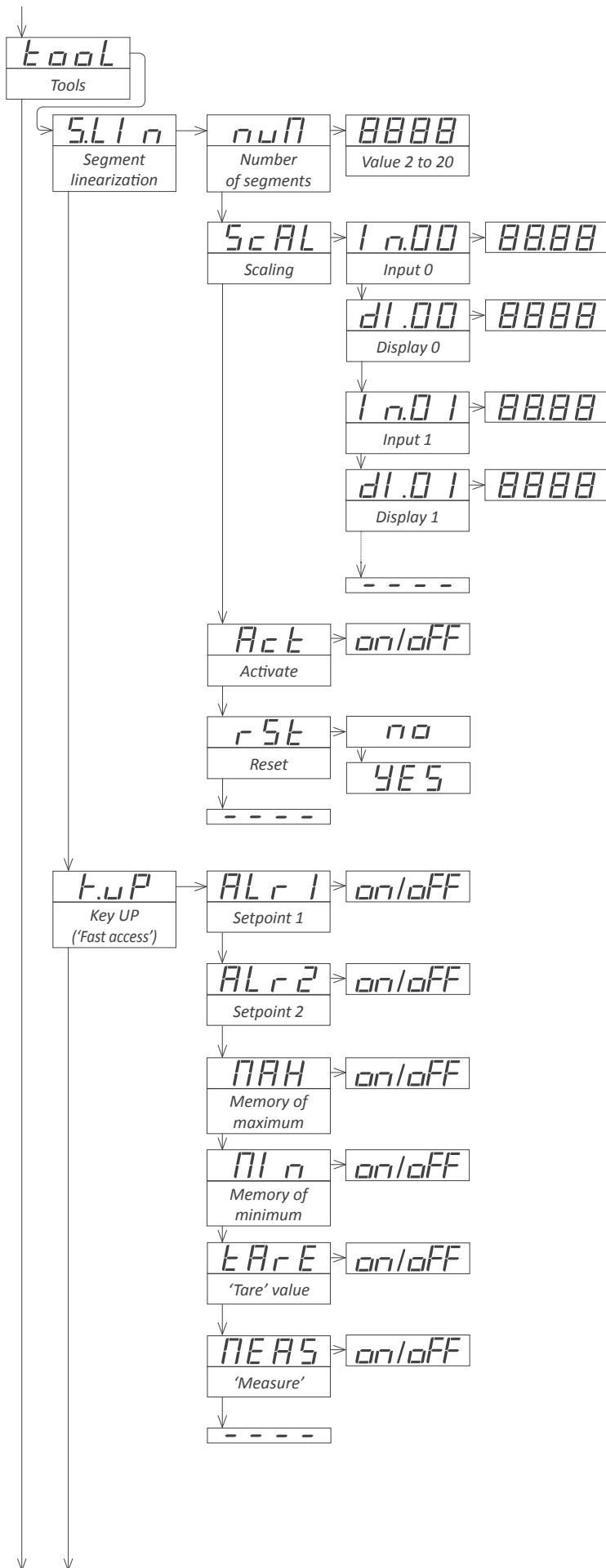

1.10.5 Segment linearization

The 'Segment Linearization' ('S.LIn') menu provides up to 20 segments to linearize non-linear signals.

- at the 'Number of segments' ('nuM') parameter, select the number of segment to use. Value between '2' and '20'.
- at the 'Scaling' ('ScAL') menu define the input signal values ('Input') and the associated reading ('Display') for each point. This menu starts at point '0' and ends at the number of segments previously defined.
- the 'Activate' ('Act') function activates the segment linearization, with the values previously configured. If the instrument detects error in any of the values, it will display an error message with information of the point where the error is located.
- the 'Reset' ('rSt') function resets all previously defined points and resets the 'Number of segments' ('nuM') parameter to '2' with a scaling of 0/100% of the input signal range selected and a reading of 0 to 100.

1.10.6 Fast access

The 'UP' (▲) key at the front of the instrument gives access to a list of functions configurable by the operator. See section 1.8 for an explanation on how to operate the 'fast access' menu.

The 'Key UP (Fast access)' ('K.uP') menu allows to select which functions will be accessible through the 'fast access' menu. Select 'on' to activate each function.

- the 'Setpoint 1' ('ALr1') function allows to visualize and modify the alarm 1 setpoint through the 'fast access' menu.
- the 'Setpoint 2' ('ALr2') function allows to visualize and modify the alarm 2 setpoint through the 'fast access' menu.
- the 'Memory of maximum' ('MAX') or 'Memory of minimum' ('MIn') functions allow to visualize the maximum or minimum reading value stored in memory. To reset this value, visualize the memory value at the 'fast access' menu with key UP (▲) and when message 'rSt' is displayed, press (■) to reset.
- the 'Tare value' ('tArE') function allows to visualize the actual value of the tare. See section 1.10.9 for more information.
- the 'Measure' ('MEAS') function allows to visualize the actual signal at input terminals, without scaling. Example : with an instrument with input 4/20 mA, the 'measure' function will show the direct value in mA.

1.10.7 Super fast access

If only a single function is selected for the 'fast access' menu, pressing the 'UP' (▲) key will shortly display the function name and then automatically jump to the function value.

1.10 Configuration menu (cont.)

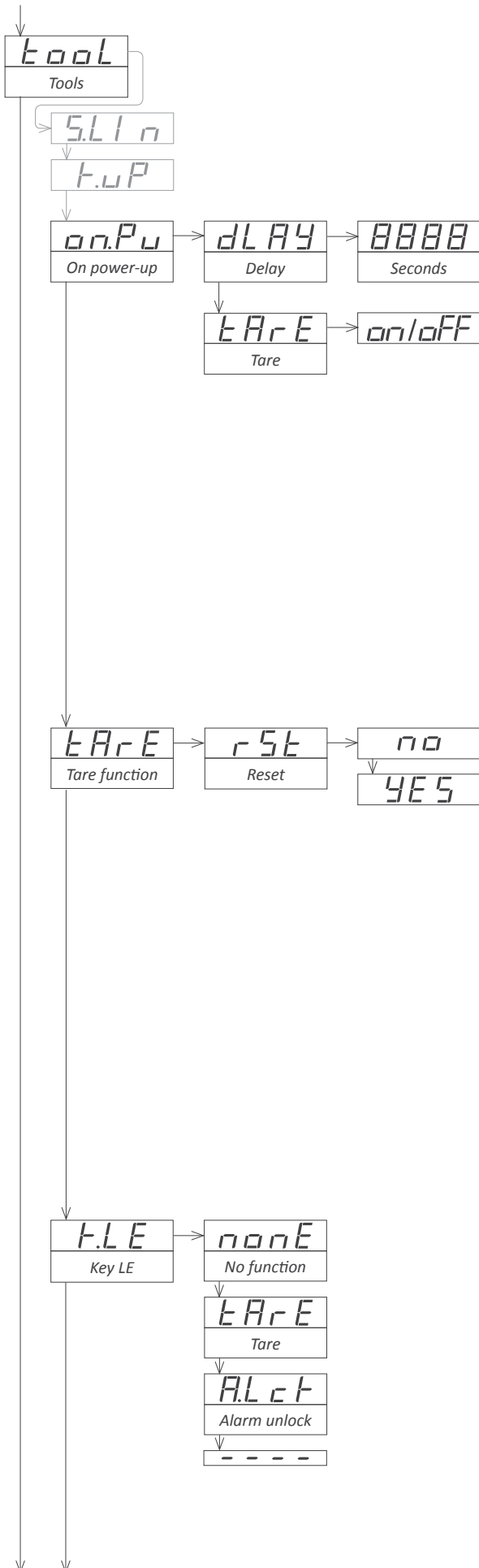

1.10.8 Menu ‘On Power Up’

The ‘On Power Up’ (‘on.Pu’) menu configures functions to apply at start-up. It applies only to instrument restart after power loss. It does not apply to instrument restart due to change in configuration.

- parameter ‘Delay’ (‘dLAY’) assigns a waiting time in seconds. The instrument waits the configured time before starting normal function. During this waiting time, the display shows all decimal points on in flash mode, all alarms are in ‘oFF’ state, there is no signal acquisition and there is no communications or control being performed. After the configured time is over, the instrument starts in normal function. Delay value between 0 and 200 seconds.

Application - the start-up process for an automation system implies that different parts of the system (engines, actuators, controllers, ...) have different start-up times. The ‘Delay’ function gives time to the instrument to wait until the slowest part of the system is fully functional before executing actions on the system (signal reading, relay activation, ...)

- the ‘Tare’ (‘tArE’) functions allow to activate an automatic tare of the reading each time the instrument is restarted. See section 1.10.9 for more information on the ‘tare’ function.

1.10.9 Menu ‘Tare function’

The ‘Tare function’ (‘tArE’) menu allows to operate the instrument for load-cell and weight applications. The tare function assigns the actual input signal value to a reading of ‘0’ Kilos, by adding an internal offset. It does not modify the scaling parameters of the instrument.

The ‘Tare’ function can be applied pressing button ‘LE’ (◀) at the front keypad (see section 1.10.10). The offset value is eligible for visualization through the ‘Fast access’ menu (see section 1.10.6).

To work with load-cell applications it is important to first adjust the scaling of the instrument to the load-cell used.

Application - A load cell with 2 mV/V parameter, powered at 10 Vdc, with nominal weight of 500 Kilos, together with a signal converter that provides 4/20 mA signals for a 0/20 mV signal from the load-cell. The scaling to configure at the meter is 4/20 mA = 0/500.0 Kilos. Once the meter is scaled, the tare function can be used to ‘tare’ the reading to 0 Kilos.

- at the ‘Reset’ (‘rSt’) menu select ‘yES’ to reset the tare offset value in memory.

1.10.10 Menu ‘Key LE’

The ‘LE’ (◀) key at the front of the instrument can be configured to activate several functions. Only one function can be assigned to the ‘LE’ (◀) key

- the ‘No function’ (‘nonE’) value assigns no function.
- the ‘Tare’ (‘Tare’) value assigns a tare function (see section 1.10.9).
- the ‘Alarm unlock’ (‘A.Lck’) value assigns the manual unlock of the alarms function, for instruments with the ‘Locked alarms’ (‘A.Lck’) function activated (see section 1.10.3)

1.10 Configuration menu (cont.)

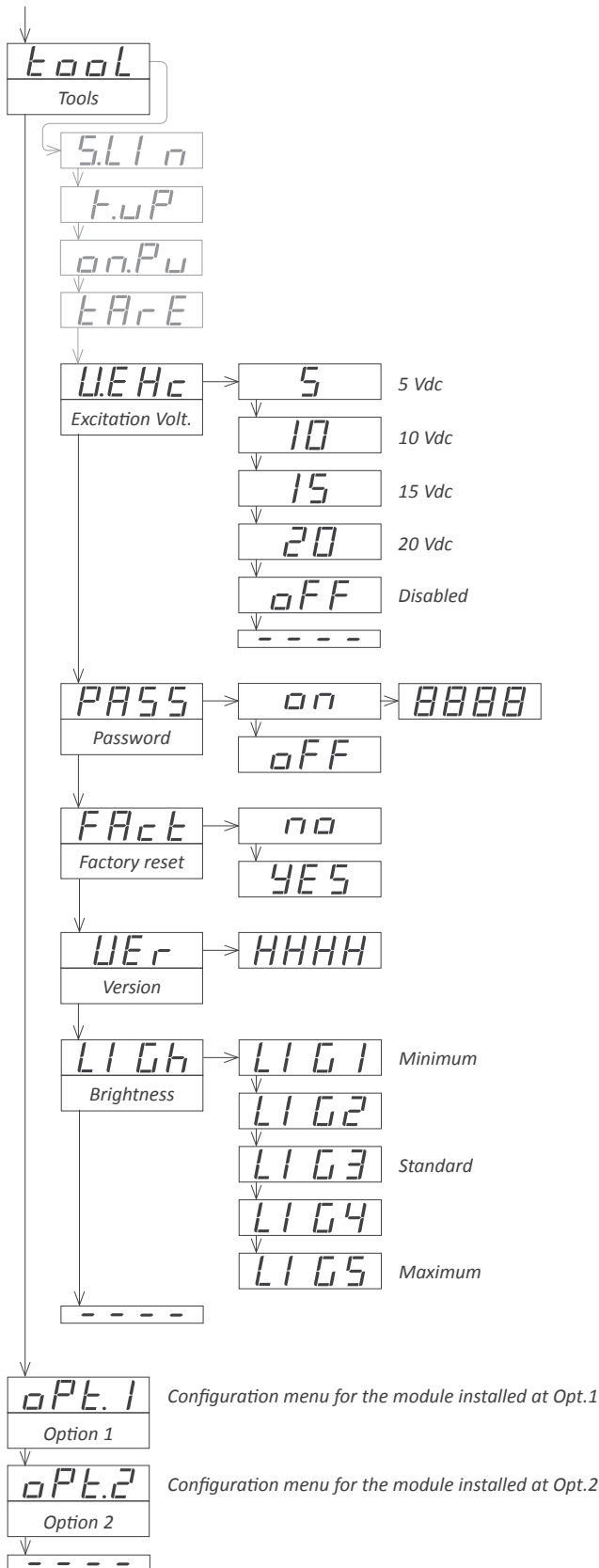

1.10.11 Excitation voltage

At the 'Excitation Volt' ('V.EXc') menu select the excitation voltage value at 5 Vdc, 10 Vdc, 15 Vdc or 20 Vdc. Select 'oFF' to disable the excitation voltage.

1.10.12 Function 'Password'

At the 'Password' ('PASS') menu select a 4 digit code to block access to the 'configuration menu'. Instrument configuration will not be accessible to non authorized personnel. To activate the 'Password' select 'on' and introduce the code.

The code will be requested when trying to access the 'configuration menu' (key 'SQ' (■)). The 'fast access' menu is not password protected.

1.10.13 Factory reset

At the 'Factory reset' ('FAct') menu, select 'yes' to load the default factory configuration for the instrument (see section 1.15).

1.10.14 Firmware version

The 'Version' ('VEr') menu informs of the current firmware version installed in the module.

1.10.15 Brightness

At the 'Brightness' ('LIGh') menu select the light intensity for the front leds. With this function it is possible to adapt the instrument to the environment light intensity.

1.10.16 Access to optional modules

Menus 'oPt.1' and 'oPt.2' give access to the 'configuration menus' of the output and control modules installed at slots Opt.1 and Opt.2.

See section 2 for a list of output and control modules available for each slot. The 'configuration menu' of each module is described at the User's Manual of each module.

1.11 Full configuration menu

Press 'SQ' (■) for 1 second to access the 'Configuration menu'. See section 1.10 for a description of each menu entry.

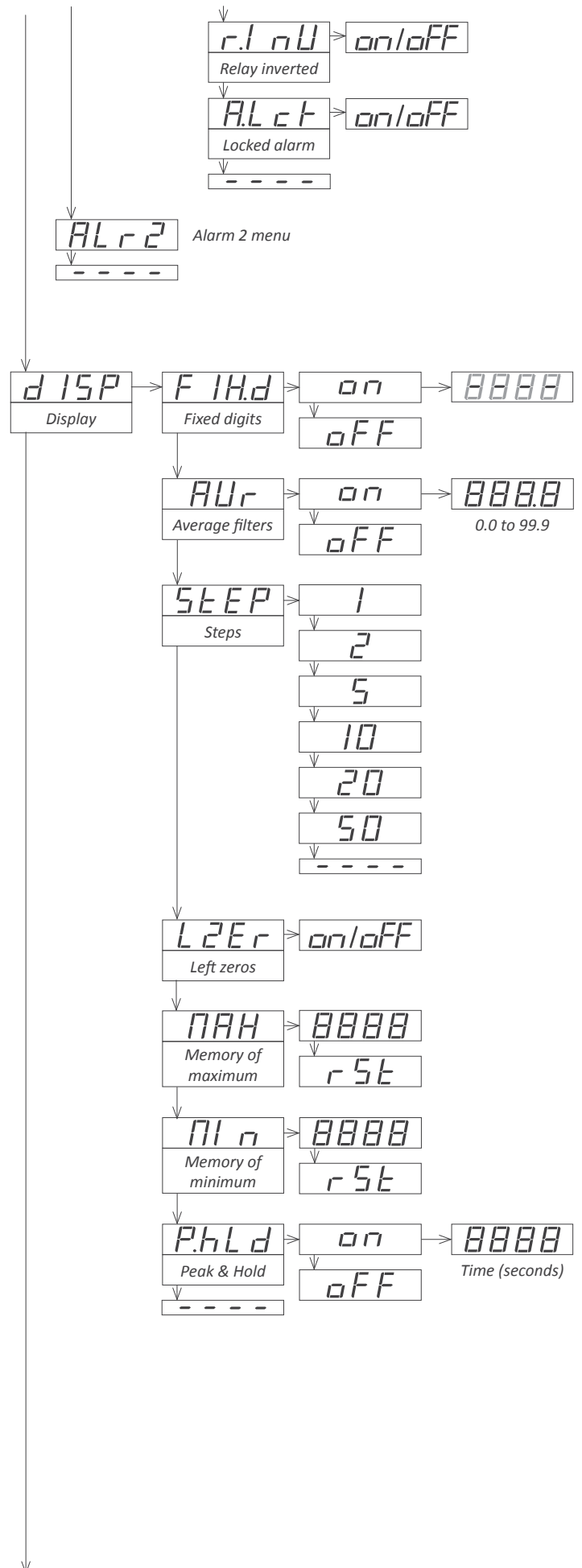
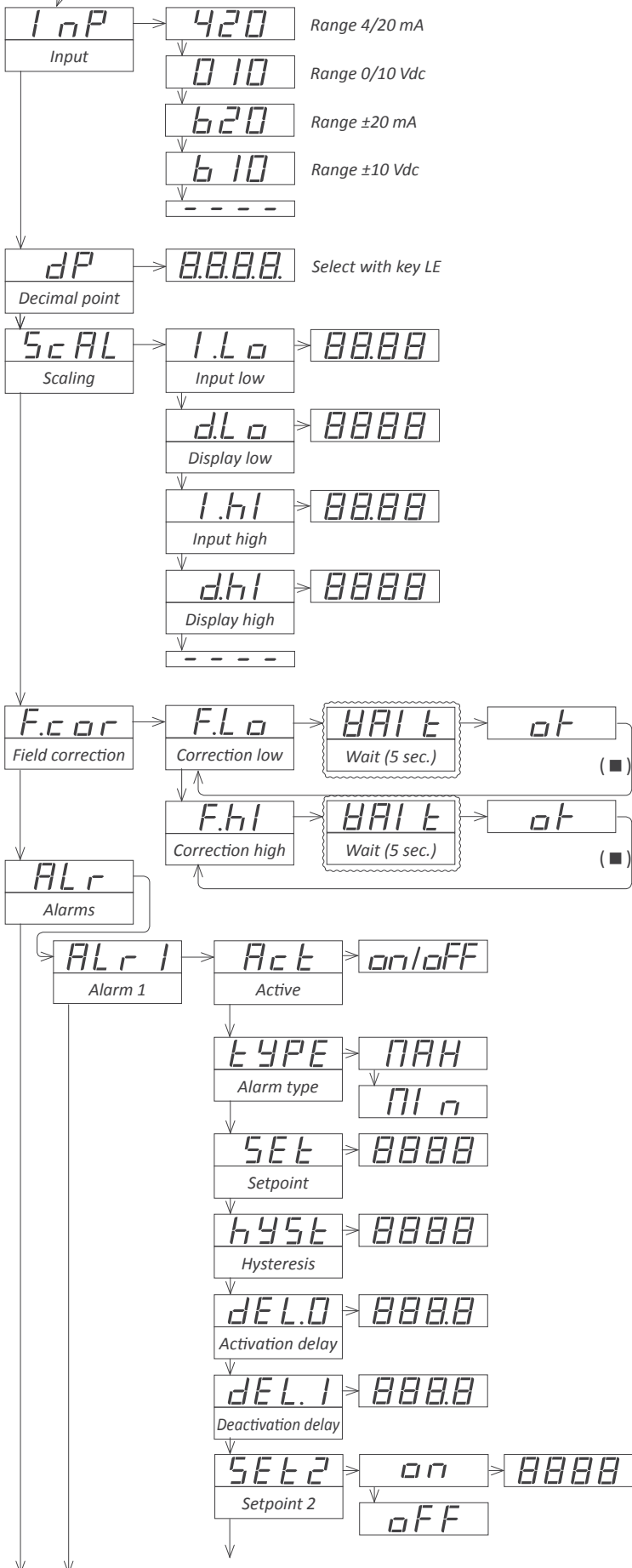

1.11 Full configuration menu (cont.)

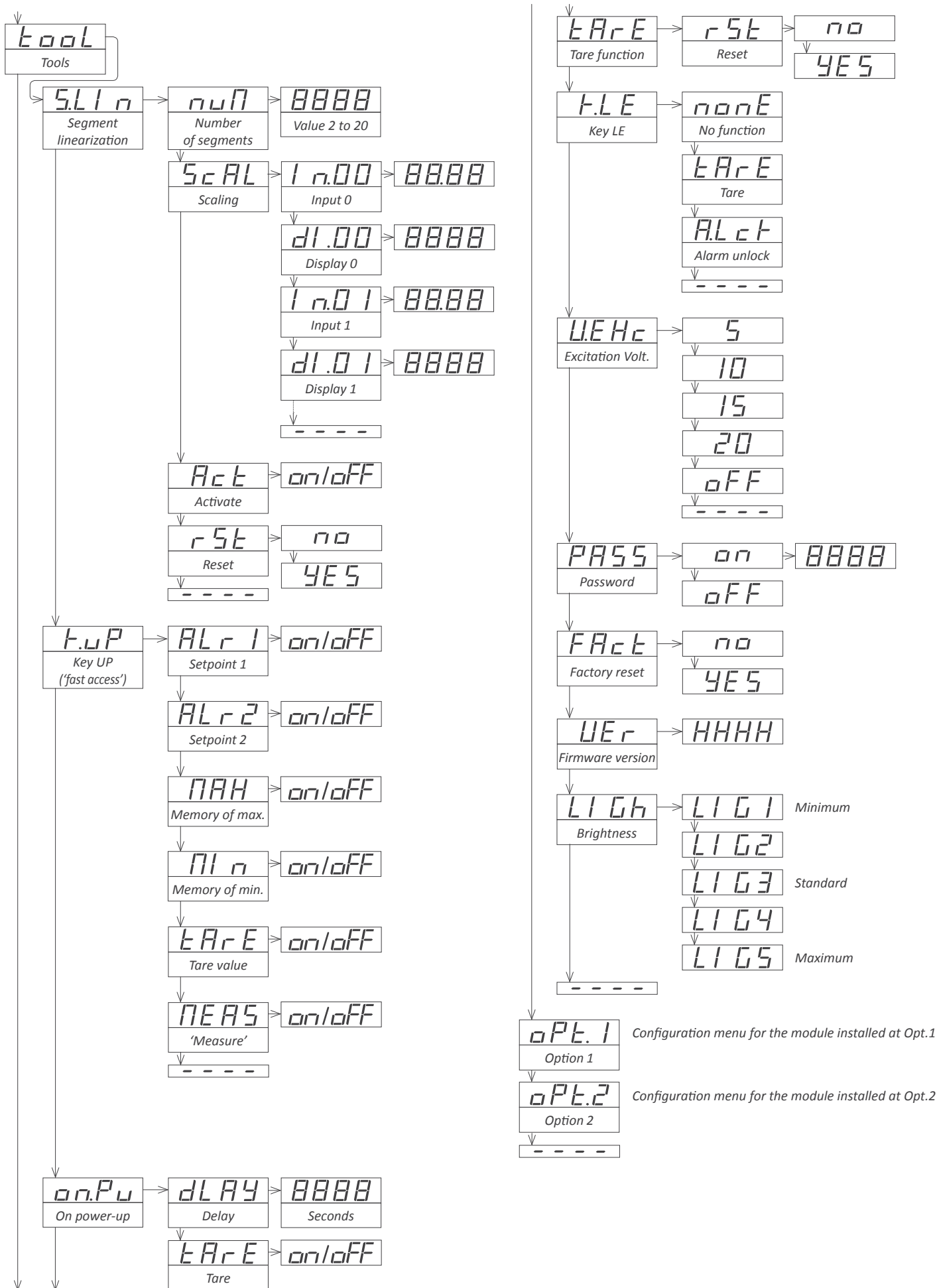

1.12 To access the instrument

You may need to access the inside of the instrument to add or replace internal modules. Use a flat screwdriver to unlock the upper clips marked with 'A'. Then unlock the lower clips marked with 'B' and remove the front cover. Let the inside of the instrument slide out of the housing.

To reinsert the instrument make sure that all modules are correctly connected to the pins on the display module. Place all the set into the housing, assuring that the modules correctly fit into the internal guiding slides of the housing. Once introduced, place again the front cover by clipping first the upper clips 'A' and then the lower clips 'B'.

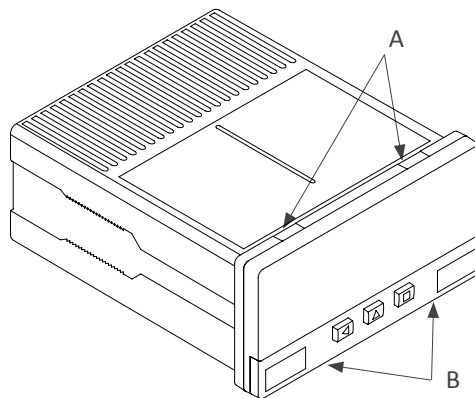

Risk of electric shock. Removing the front cover will grant access to the internal circuits. Disconnect the input signal to prevent electric shock to the operator. Operation must be performed by qualified personnel only.

1.13 Modular system

Series S panel meters are designed to create a modular system. This modular system allows for addition, replacement or substitution of any of the internal modules conforming the instrument. Below is a graphic explanation for the position of each module.

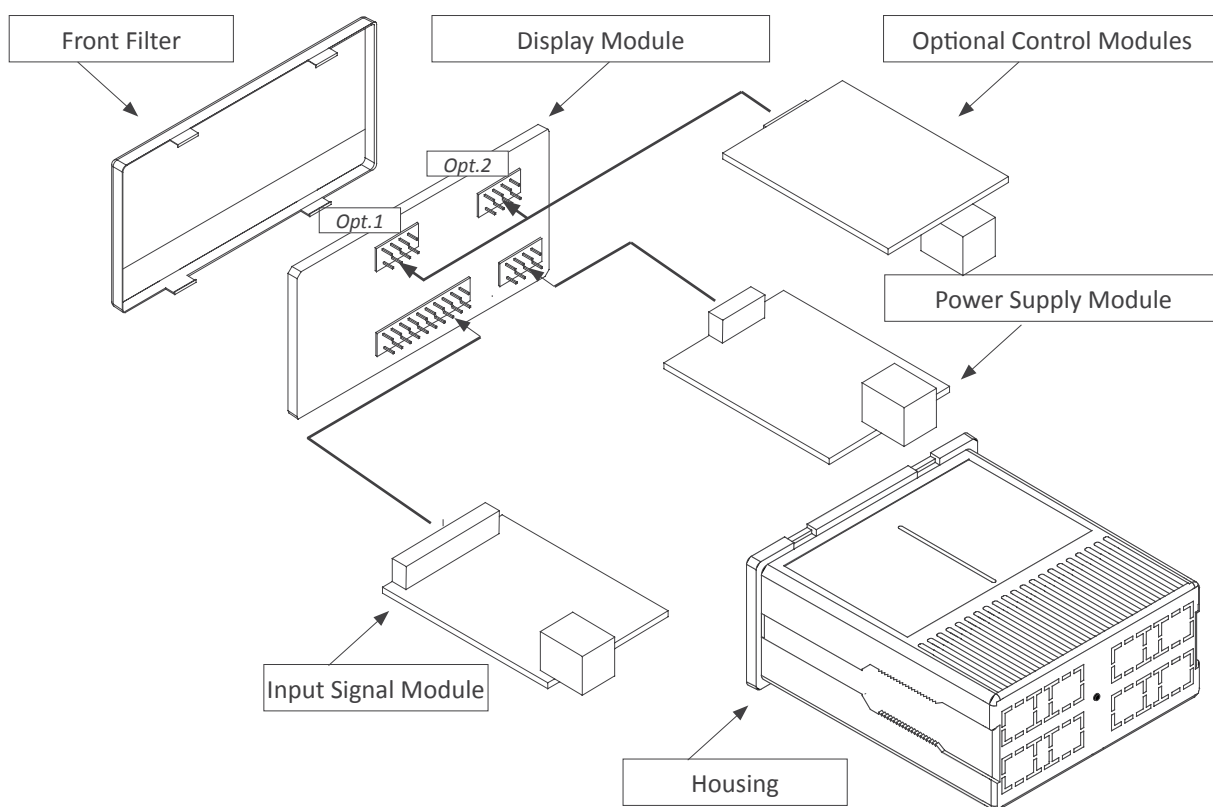

1.14 Precautions on installation



Risk of electrical shock. Instrument terminals can be connected to dangerous voltage.



Instrument protected with double isolation. No earth connection required.



Instrument conforms to CE rules and regulations.

This instrument has been designed and verified conforming to the 61010-1 CE Security Regulation, for industrial applications.

Installation of this instrument must be performed by qualified personnel only. This manual contains the appropriate information for the installation. Using the instrument in ways not specified by the manufacturer may lead to a reduction of the specified protection level. Disconnect the instrument from power before starting any maintenance and / or installation action.

The instrument does not have a general switch and will start operation as soon as power is connected. The instrument does not have protection fuse, the fuse must be added during installation.

The instrument is designed to be panel mounted. An appropriate ventilation of the instrument must be assured. Do not expose the instrument to excess of humidity. Maintain

1.15 Factory configuration

Range	4/20 mA
Scaling and decimal point	4/20 mA = 0/100.0
Alarms 1 and 2	
Active	off (disabled)
Type	alarm as maximum
Setpoint	1000
Hysteresis	0 counts
Activation delay	0.0 seconds
Deactivation delay	0.0 seconds
Setpoint 2	off
Inverted relay	off
Locked alarms	off
Display	
Fixed digits	off
Average	off
Steps	off
Left zeros	off
Maximum memory	-1999
Minimum memory	9999
Peak&Hold	off
Tools	
Segment linearization	off
'Fast access'	off
'On power-up'	
Delay	0 seconds
Tare	off
Key LE	no function
Excitation voltage	+20 Vdc
Password	off
Brightness	3

1.16 Warranty

This instrument is warranted against all manufacturing defects for a period of 24 MONTHS from the shipment date. This warranty does not apply in case of misuse, accident or manipulation by non-authorized personnel. In case of malfunction get in contact with your local provider to arrange for repair. Within the warranty period and after examination by the manufacturer, the unit will be repaired or substituted when found to be defective. The scope of this warranty is limited to the repair cost of the instrument, not being the manufacturer eligible for responsibility on additional damages or costs.

clean by using a humid rag and do NOT use abrasive products such as alcohols, solvents, etc.

General recommendations for electrical installations apply, and for proper functionality we recommend : if possible, install the instrument far from electrical noise or magnetic field generators such as power relays, electrical motors, speed variators, ... If possible, do not install along the same conduits power cables (power, motor controllers, electrovalves, ...) together with signal and/or control cables.

Before proceeding to the power connection, verify that the voltage level available matches the power levels indicated in the label on the instrument.

In case of fire, disconnect the instrument from the power line, fire alarm according to local rules, disconnect the air conditioning, attack fire with carbonic snow, never with water.

1.17 CE declaration of conformity

Manufacturer FEMA ELECTRÓNICA, S.A.
 Altimira 14 - Pol. Ind. Santiga
 E08210 - Barberà del Vallès
 BARCELONA - SPAIN
 www.fema.es - info@fema.es

Products S40-P

The manufacturer declares that the instruments indicated comply with the directives and rules indicated below.

Electromagnetic compatibility directive 2014/30/EU

Low voltage directive 2014/35/EU

Directive ROHS 2011/65/EU

Security rules EN-61010-1

Instrument Fixed
 Permanently connected
 Pollution degree 1 and 2 (without condensation)
 Isolation Double

Electromagnetic compatibility rules EN-61326-1

EM environment Industrial

Immunity levels

EN-61000-4-2	By contact ± 4 KV By air ± 8 KV	Criteria B Criteria B
EN-61000-4-3		Criteria A
EN-61000-4-4	On AC power lines : ± 2 KV On DC power lines : ± 2 KV On signal lines : ± 1 KV	Criteria B Criteria B Criteria B
EN-61000-4-5	Between AC power lines ± 1 KV Between AC power lines and earth ± 2 KV Between DC power lines ± 1 KV Between DC power lines and earth ± 2 KV Between signal lines and earth ± 1 KV	Criteria B Criteria B Criteria B Criteria B Criteria B
EN-61000-4-6		Criteria A
EN-61000-4-8	30 A/m at 50/60 Hz	Criteria A
EN-61000-4-11	0 % 1 cycle 40 % 10 cycles 70 % 25 cycles 0 % 250 cycles	Criteria A Criteria A Criteria B Criteria B

Emission levels

CISPR 11 Instrument Class A, Group 1 Criteria A

Barberà del Vallès October 2017

Xavier Juncà - Product Manager



According to directive 2012/19/EU, electronic equipment must be recycled in a selective and controlled way at the end of its useful life.

2. Output and control modules

2.1 Module R1

The R1 module provides 1 relay output to to install at digital panel meters from Series S, up to a maximum of 2 relays in a single meter.

Note : for more than 2 relays per instrument or larger relay density per module, see special modules R2 and R4.

Configuration is performed from the frontal keypad of the meter, by setting the parameters at the alarm menu. Check the parameters of at the alarm menu for full information.

Relay with 3 contacts (common, normally open, normally closed) with up to 250 Vac switching voltage and 8 A.

Modules R1 can be ordered pre-installed into a Series S digital panel meter, or standalone for delayed installation, as they do not require soldering or special configuration.

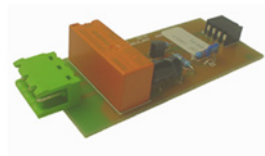

Type of relay	3 contact relay (NC, NO, common)
Current maximum	8 A per relay (resistive load)
Voltage maximum*	250 Vac continuous
Isolation	3500 Veff
Type of terminal	plug-in screw terminal, pitch 5.08 mm
Slots allowed	'Opt.1', 'Opt.2'

Terminal A Common
 Terminal B NO - Normally open
 Terminal C NC - Normally closed

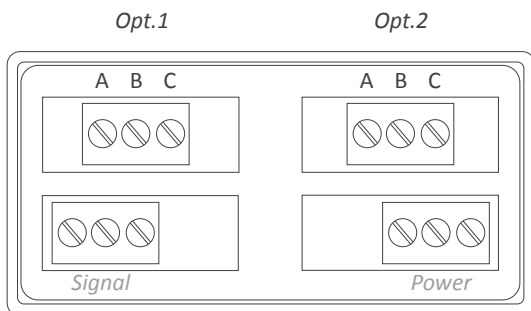

For more information : http://fema.es/docs/4254_SERIES_M-K-S_OPTIONS_manual_i.pdf

2.2 Module T1

The T1 module provides 1 transistor output to install at digital panel meters from Series S, up to a maximum of 2 transistors in a single meter.

Configuration is performed from the frontal keypad of the meter, by setting the parameters at the alarm menu. Check the parameters of at the alarm menu for full information.

Transistor output is optoisolated, provides 2 terminals for connection, and can switch up to 35 V and 50 mA.

Modules T1 can be ordered pre-installed into a Series S digital panel meter, or standalone for delayed installation, as they do not require soldering or special configuration.

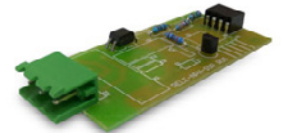

Type of output	transistor
Max. voltage	35 Vdc
Max. current	50 mA
Isolation	3500 Veff
Type of terminal	plug-in screw terminal, pitch 5.08 mm
Slots allowed	'Opt.1', 'Opt.2'

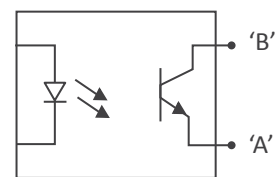

Schematic for T1 output

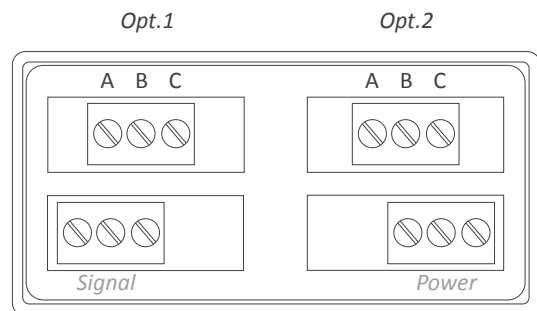

For more information : http://fema.es/docs/4254_SERIES_M-K-S_OPTIONS_manual_i.pdf

2.3 Module SSR

The SSR module provides 1 output to control SSR relays, to install at digital panel meters from Series S, up to a maximum of 2 SSR controls in a single meter.

Configuration is performed from the frontal keypad of the meter, by setting the parameters at the alarm menu. Check the parameters of at the alarm menu for full information.

The module provides +15 Vdc voltage and up to 45 mA.

Modules SSR can be ordered pre-installed into a Series S digital panel meter, or standalone for delayed installation, as they do not require soldering or special configuration.

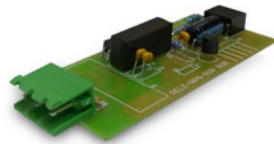

Type of output	to control an SSR relay
Voltage output	15 Vdc
Max. current	45 mA
Isolation	1000 Vdc
Type of terminal	plug-in screw terminal, pitch 5.08 mm
Slots allowed	'Opt.1', 'Opt.2'

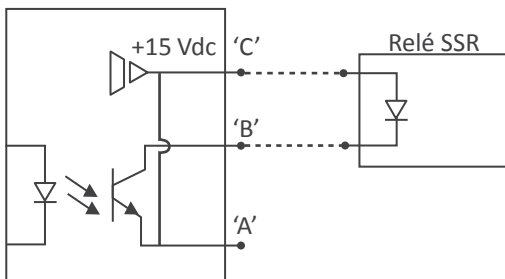

Schematic for SSR control module

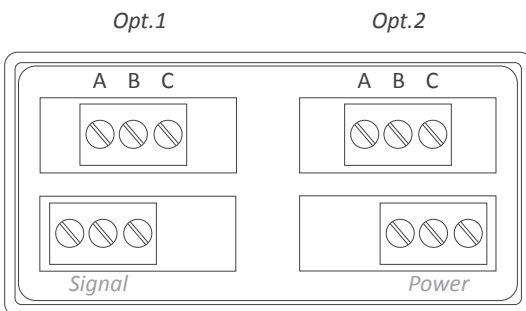

2.4 Module AO

The AO module provides 1 analog output with 4/20 mA or 0/10 Vdc configurable output range. Output current loop configurable as active (the instrument provides the excitation for the loop) or passive (the loop is externally powered). Signal output proportional to the instruments reading. Fully configurable scaling, in direct (positive slope) or inverse (negative slope) scaling.

Up to a maximum of 2 analog output modules can be installed in a single instrument, all outputs isolated between them and isolated from the power and input signal circuits.

Configuration from instrument front keypad, through menu entries 'Opt.1' or 'Opt.2', depending on the position the module is installed.

The AO module can be ordered pre-installed into a Series S panel meter, or standalone for delayed installation, as it does not require soldering or special configuration.



Output ranges	4/20 mA active, 4/20 mA passive 0/10 Vdc
Accuracy (at 25 °C)	<0.1% FS
Isolation	1000 Vdc
Slots allowed	'Opt.1', 'Opt.2'

Terminal A	Vexc
Terminal B	Signal in mA or Vdc
Terminal C	GND
Jumper M	closed for mA
Jumper V	closed for Vdc

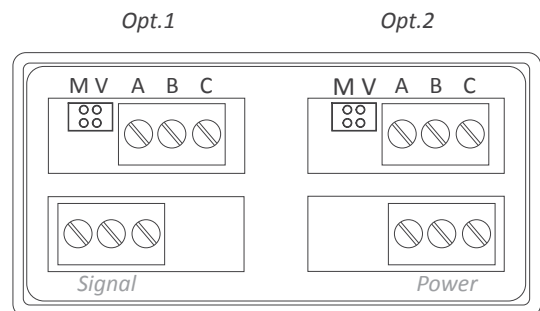

For more information : http://fema.es/docs/4254_SERIES_M-K-S_OPTIONS_manual_i.pdf

For more information : http://fema.es/docs/4254_SERIES_M-K-S_OPTIONS_manual_i.pdf

2.5 Module RTU

The RTU module provides a Modbus RTU communications module for Series S of panel meters. The RTU module implements function '4' ('Read Input Registers') of the Modbus RTU protocol, to access the instrument registers (reading value, alarm status, memory of maximum and minimum, ...)

Configuration from instrument front keypad, through menu entries 'Opt.1' or 'Opt.2', depending on the position the module is installed.

The RTU module can be ordered pre-installed into a Series S panel meter, or standalone for delayed installation, as it does not require soldering or special configuration.



Protocol	Modbus RTU
Functions implemented	4 (Read_Input_Registers)
Bus type	RS-485, up to 57.6 Kbps
Isolation	1000 Vdc
Slots allowed	'Opt.1', 'Opt.2'

Terminal B B signal from RS-485 bus
 Terminal A A signal from RS-485 bus
 Terminal G GND

Opt.1 Opt.2

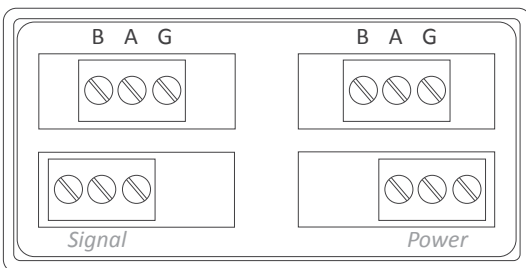

For more information : http://fema.es/docs/4254_SERIES_M-K-S_OPTIONS_manual_i.pdf

2.6 Module S4

The S4 module provides a RS-485 communications module for Series S of panel meters. ASCII protocol with 'Master' / 'Slave' architecture. Addressable with up to 31 modules. Frames codified in representable ASCII characters (codes 32 to 255), directly visible using 'hyper-terminal' or similar programs.

- Configurable for direct retransmission to remote meters M60-485 (14 mm digit height) and BDF Series (60 mm and 100 mm digit height).

- Access to display values, alarm status, memory of maximum and minimum, alarm setpoints, ...

Configuration from instrument front keypad, through menu entries 'Opt.1' or 'Opt.2', depending on the position the module is installed.

The S4 module can be ordered pre-installed into a Series S panel meter, or standalone for delayed installation, as it does not require soldering or special configuration.



Protocol	ASCII
Bus type	RS-485, up to 57.6 Kbps
Isolation	1000 Vdc
Slots allowed	'Opt.1', 'Opt.2'

Terminal B B signal from RS-485 bus
 Terminal A A signal from RS-485 bus
 Terminal G GND

Opt.1 Opt.2

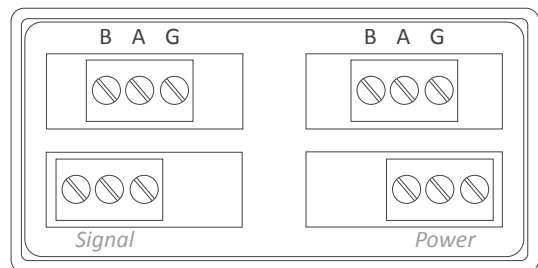

For more information : http://fema.es/docs/4254_SERIES_M-K-S_OPTIONS_manual_i.pdf

2.7 Module S2

The S2 module provides a RS-232 communications module for Series S of panel meters. ASCII protocol with 'Master' / 'Slave' architecture. Addressable with up to 31 modules. Frames codified in representable ASCII characters (codes 32 to 255), directly visible using 'hyper-terminal' or similar programs.

- Access to display values, alarm status, memory of maximum and minimum, alarm setpoints, ...

Configuration from instrument front keypad, through menu entries 'Opt.1' or 'Opt.2', depending on the position the module is installed.

The S2 module can be ordered pre-installed into a Series S panel meter, or standalone for delayed installation, as it does not require soldering or special configuration.



Protocol	ASCII
Bus type	RS-232, up to 57.6 Kbps
Isolation	1000 Vdc
Slots allowed	'Opt.1', 'Opt.2'

Terminal E	GND
Terminal D	Rx1
Terminal C	Tx1
Terminal B	Rx2
Terminal A	Tx2

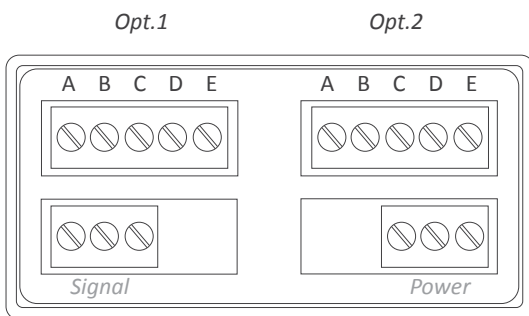

For more information : http://fema.es/docs/4254_SERIES_M-K-S_OPTIONS_manual_i.pdf

2.8 Modules R2, R4

The R2 and R4 modules provide 2 and 4 relay outputs for Series S panel meters. Relays with 3 contacts each, with switching capability up to 250 V @ 6 A.

Modules R2 and R4 are installed on slot 'Opt.1' and are configured from instruments front keypad, and provide setpoint configuration, hysteresis, independent activation and deactivation delays, and second alarm setpoint for windowed alarms.

Only one module R2 or R4 can be installed per instrument. Modules R2 and R4 are not compatible with standard R1, T1 and SSR modules.

The R2 and R4 modules can be ordered pre-installed into a Series S panel meter, or standalone for delayed installation, as they do not require soldering or special configuration.



Type of relay	3 contact relay (NC, NO, common)
Current maximum	6 A per relay (resistive load)
Voltage maximum*	250 Vac continuous
Isolation	2500 Veff
Type of terminal	plug-in screw terminal, pitch 3.81 mm
* terminals approved for 300 V (according to UL1059, groups B and D) and 160 V (according to VDE on CAT-III and pollution degree 3).	
Module R2	occupies Opt.1
Module R4	occupies Opt.1 and Opt.2

Relay	Common	Normally Open (NO)	Normally Closed (NC)
relay 1	A	B	C
relay 2	D	E	F
relay 3	G	H	I
relay 4	J	K	L

Table 4 - Connections for modules R2 and R4

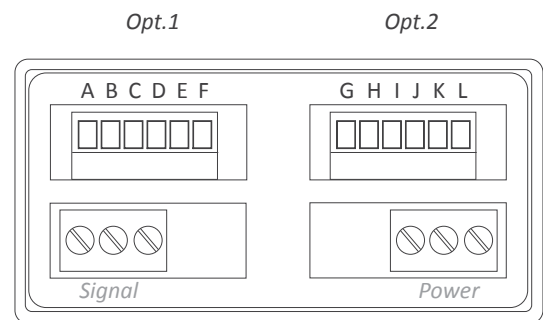

For more information : http://fema.es/docs/4254_SERIES_M-K-S_OPTIONS_manual_i.pdf



Panel meters
Standard 96x48 mm



Large format meters



Panel meters
Compact 72x36 mm



Bar meters



Signal converters



Panel meters
Miniature 48x24 mm



Isolators



Low Cost



'Customized'
instruments

FEMA

ELECTRÓNICA

FEMA ELECTRÓNICA, S.A.

Altimira 14 - Pol. Ind. Santiga
E08210 Barberà del Vallès
BARCELONA - SPAIN

■ Tel. +34 93.729.6004
Fax +34 93.729.6003

■ info@fema.es
www.fema.es



Process



°C
°F



160 RPM



Vac/Aac



Vdc/Adc



Hz



Modbus



BCD



Kg



RS-485



RS-232

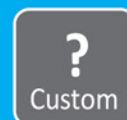

Custom